

## NOTICE

A meeting of the City of Evansville Plan Commission will be held on the date and time stated below. Notice is further given that members of the City Council and Historic Preservation Commission may be in attendance. Requests for persons with disabilities who need assistance to participate in this meeting should be made by calling City Hall at (608)-882-2266 with as much notice as possible.

City of Evansville **Plan Commission**  
Regular Meeting  
City Hall, 31 S Madison St., Evansville, WI 53536  
Tuesday, April 4, 2023, 6:00 pm

## AGENDA

1. Call to Order
2. Roll Call
3. Motion to Approve Agenda
4. Motion to waive the reading of the minutes from the February 7, 2023 meeting and approve them as printed.
5. Civility Reminder
6. Citizen appearances other than agenda items listed
7. Action Items
  - A. Review of Site Plan Application 2022-0252 on parcel 6-27-958.091A1 (777 Brown School Road, 783-785 Brown School Road)
    1. Staff Report and Applicant Comments
    2. Commission Questions and Comments
    3. Final Motion with Conditions
  - B. Discussion and Motion to Recommend to Common Council Approval of Amendment #1 to the Development Agreement on parcel 6-27-958.091A1.
  - C. Review and Action on Land Division Application 2023-0047 and Rezoning Application 2023-0048 on parcels 6-27-559.5170 and 6-27-559.5171 (Lots 170 and 171, Westfield Meadows)
    1. Review Staff Report and Applicant Comments
    2. Public Hearing
    3. Plan Commissioner Questions and Comments
    4. Motion with Conditions
  - D. Review of Conditional Use Application 2022-0054 for an Indoor Commercial Entertainment Use (Main Street Fix) on parcel 6-27-25 (8 W Main Street).
    1. Review Staff Report and Applicant Comments
    2. Public Hearing
    3. Plan Commissioner Questions and Comments

*-Mayor Dianne Duggan, Plan Commission Chair*

4. Motion with Conditions
- E. Review of Conditional Use Application 2022-0059 for Light Industrial Use Incidental to Indoor Sales (Hop Garden) on parcel 6-27-6 (18 E Main Street).
  1. Review Staff Report and Applicant Comments
  2. Public Hearing
  3. Plan Commissioner Questions and Comments
  4. Motion with Conditions
- F. Review of Conditional Use Application 2022-0060 for a new structure in the Historic Conservation Overlay District on parcel 6-27-894.1 (30 Railroad Street).
  1. Review Staff Report and Applicant Comments
  2. Public Hearing
  3. Plan Commissioner Questions and Comments
  4. Motion with Conditions
- G. Discussion and Motion to Recommend to Common Council Approval of Ordinance 2023-03, Amending Chapter 130, Article IV Landscaping Regulations
8. Discussion Items
9. Community Development Report
10. Upcoming Meetings
  - A. Plan Commission Meeting: Tuesday, May 1, 2023 at 6:00pm
11. Motion to Adjourn

*-Mayor Dianne Duggan, Plan Commission Chair*

*These minutes are not official until approved by the City of Evansville Plan Commission.*

**City of Evansville Plan Commission  
Regular Meeting  
Tuesday, February 7, 2023, 6:00 p.m.**

**MINUTES**

**1. Call to Order** at 6:00pm.

**2. Roll Call:**

<b>Members</b>	<b>Present/Absent</b>	<b>Others Present</b>
Mayor Dianne Duggan	P	Colette Spranger (Community Dev. Director)
Aldersperson Cory Neeley	P	Joe Rohloff (applicant)
Aldersperson Susan Becker	P	Derek Blume
Abbey Barnes	P	Alvin Francis
John Gishnock	P	Andy Phillips (applicant)
Mike Scarmon	P	Derek Allen
Eric Klar	P	Jason Sergeant (City Administrator) Bill Lathrop (Evansville Today)

**3. Motion to approve the agenda, by Neeley, seconded by Klar. Approved unanimously**

**4. Motion to waive the reading of the minutes from the January 3rd, 2023 meetings and approve them as printed, by Neeley, seconded by Klar. Approved unanimously.**

**5. Civility Reminder.** Duggan noted the City's commitment to conducting meetings with cordiality.

**6. Citizen appearances other than agenda items listed.**

- A.** Alvin Francis, Town of Union Plan Commission Chair reported that the Town Plan Commission recommended approval of its first housing development in 17 years on January 29<sup>th</sup>. It will go before the Town Board on February 14<sup>th</sup>. He is expecting the City to make a decision regarding the preliminary plat application that was submitted to the City. Spranger replied that she is reviewing the application and will make a response soon.

**7. Action Items**

- A. Review and Action on Preliminary/Final Land Division Application 2022-0318 on parcel 6-27-533.506 (Lot 6, Stonewood Grove)**

**1. Review Staff Report and Applicant Comments**

Applicant Noah Hurley was not present. Spranger summarized the report, noting that it was very similar to prior zero lot CSMs issued over the past year.

**2. Public Hearing**

*These minutes are not official until approved by the City of Evansville Plan Commission.*

Mayor Duggan opened the public hearing at 6:04pm. No comments. Public hearing closed at 6:05pm.

**3. Plan Commissioner Questions and Comments**

None.

**4. Motion with Conditions**

**Motion to approve a certified survey map to divide parcel 6-27-533.506 into two lots for a two-family twin residence, located at 642 and 644 Locust Lane, finding that the application is in the public interest and meets the objectives contained within Section 110-102(g) of city ordinances, with the condition that the CSM and joint cross access and maintenance agreement are recorded for both lots with Rock County Register of Deeds.**

*Motion by Neeley, seconded by Klar. Approved unanimously*

**B. Review and Action on Preliminary/Final Land Division Application 2023-0014 on parcel 6-20-217 (7538 N. Territorial Road, Town of Union)**

**1. Review Staff Report and Applicant Comments**

Spranger summarized the application and noted that it met the City's guidelines for land divisions within the extraterritorial jurisdiction.

**2. Public Hearing**

Mayor Duggan opened the public hearing at 6:04pm. No comments. Public hearing closed at 6:05pm.

**3. Plan Commissioner Questions and Comments**

None.

**4. Motion with Conditions**

**Motion to recommend that Common Council approve the creation of a 3.5 acre residential lot from parcel 6-20-217, a 118.5 acre parcel located at 7538 N. Territorial Road, Town of Union, finding that the application is in the public interest and meets the objectives contained within Sections 110-230 and 110-102(g) of city ordinances, with the condition the final CSM is recorded with Rock County Register of Deeds, and that the application fulfills the other obligations set forth by the Town of Union and Rock County.**

*Motion by Neeley, seconded by Klar. Approved unanimously*

**C. Review and Action on Final Land Division Application 2023-0031 on parcel 6-27-580 (near 210 Cemetery Road)**

**1. Review Staff Report and Applicant Comments**

Spranger summarized the changes between this final CSM and the preliminary one that was approved in May. Namely, the location of lot lines were adjusted to ensure that future subdivisions of the four lots could occur and remain in compliance with the City's Municipal Code. The City is also requesting that the right-of-way for a public street be dedicated to the public now as opposed to reserved.

**2. Public Hearing**

*These minutes are not official until approved by the City of Evansville Plan Commission.*

Mayor Duggan opened the public hearing at 6:12pm. No comments. Public hearing closed at 6:12pm.

### 3. Plan Commissioner Questions and Comments

None.

### 4. Motion with Conditions

**Motion to approve a final certified survey map to divide parcel 6-27-580 into four lots, finding that the application is in the public interest and meets the objectives contained within Section 110-102(g) of city ordinances, subject to the following conditions:**

- a. **Private well and septic systems will be sited and will conform to standards set by the State of Wisconsin.**
- b. **One well and one septic system will be allowed per lot created by this CSM.**
- c. **Further division of any lot created by this CSM is contingent upon serviceability by City utilities. Future lots created will conform to the standards of Chapter 130 of the Evansville Municipal Code.**
- d. **Upon development of Exodus Pass:**
  - i. **The City shall give the landowner 48 months notice to connect to City sanitary sewers. Upon abandonment of the septic system, the tanks shall be remediated per Sec 126-360 and 126-361 of the Municipal Code**
  - ii. **The landowner will install sidewalks and driveways meeting the standards of the Municipal Code.**
- e. **The final CSM is recorded with Rock County Register of Deeds.**

*Motion by Neeley, seconded by Becker. Approved unanimously*

### 8. Discussion Items

- A. Update on Site Plan Application 2022-0252 on parcel 6-27-958.091A1 (777 Brown School Road, 783-785 Brown School Road)
  1. Site Plan in Compliance
  2. Development Agreement

Spranger brought the Commission up to speed on ongoing conversations between the City and applicant. The site plan is in a position where Spranger would feel comfortable recommending its approval at the March meeting. The next issue is the development agreement. The original for this site was convoluted and unclear in how and when incentives were to be distributed.

Mr. Phillips submitted some conceptual plans for a third building on the site. He would like to do more residential than was previously approved and was seeking feedback from the Commission. Commission members were receptive to the idea.

### 9. Community Development Report

- A. Wisconsin State Statutes and Wireless Facilities

Spranger provided some background information concerning the ability municipalities have to control where and how telecommunication facilities are placed.

### 10. Next Meeting Date:

*These minutes are not official until approved by the City of Evansville Plan Commission.*

A. March 7, 2023 at 6:00 p.m.

**11. Motion to Adjourn at 6:48p.m. by Neeley, seconded by Scarmon. Approved unanimously.**

**SITE PLAN REVIEW – STAFF REPORT****Applicant: Phillips-Morning Development Group, Parcel 6-27-958.091A****(Brown School Road, Lot 2)****March 30, 2023**

Prepared by: Colette Spranger, Community Development Director

Direct questions and comments to: [colette.spranger@ci.evansville.gov](mailto:colette.spranger@ci.evansville.gov) or 608-882-2263

**Description of request:** The applicant is seeking approval of a Site Plan for two existing commercial buildings and completion of project site work.

**Staff Analysis of Request:** The request includes parking, driveways, site grading, and landscaping elements. The proposal allows space for a third commercial building abutting US Highway 14. A new site plan application will need to be submitted when the third building is developed.

The intention of this resubmittal is to reflect the site as it currently stands and plan for an outcome where the third building does not get built. The applicant intends to build a third building at a later date. The only conditions I am recommending for tonight is that the applicant agrees to install the curbing as outlined in red on the site plan that is included in this packet and to relocate some of the proposed arborvitae to the parking area between the residential building and Brown School Plaza in order to screen in from view along Highway 14. Additional landscaping is not needed; the site has sufficient landscape points per the Zoning Code. Parking is sufficient for the intended uses.

Per Section 130-109 of the City's Zoning Code, the applicant has two years to finish any outstanding work depicted on this site plan. If a new site plan is submitted for a third building during the next two years, then that new site plan will supersede this one.

City staff and the applicant have been engaged in ongoing discussion regarding the TIF incentives and Development Agreement associated with this parcel. As evidenced by Item 7B on tonight's agenda, both parties have come to a mutual conclusion to nullify the Development Agreement.

**Required Plan Commission findings for Site Plan request:** Section 130 of the Municipal Code, includes criteria that should be considered in making this decision:

1. **Consistency of the use with the comprehensive plan.** The proposed use in general and in this specific location is consistent with the city's comprehensive plan.  
*Staff Comment: The Comprehensive plan indicates a desire to encourage expansion of existing businesses. The development achieves this by providing business expansion spaces and new commercial buildings on site.*
2. **Consistency with the city's zoning code, or any other plan, program, or ordinance.** The proposed use in general and in this specific location is consistent with City's zoning code,

or any other plan, program, or ordinance, whether adopted or under consideration pursuant to official notice of the city.

*Staff comment: The applicant has received conditional use permits for the property. The proposed uses are permitted and are consistent with city's zoning code.*

3. **Effect on nearby property.** The use will not result in a substantial or undue adverse impact on nearby property, the character of the neighborhood, environmental factors, traffic factors, parking, public improvements, public property or rights-of-way, or other matters affecting the public health, safety, or general welfare, either as they now exist or as they may in the future be developed as a result of the implementation of the city's zoning code, the comprehensive plan, or any other plan, program, map, or ordinance adopted or under consideration pursuant to official notice by the city.

*Staff Comment: The proposed buildings are consistent with other commercial construction and zoning along Brown School Road.*

4. **Appropriateness of use.** The use maintains the desired consistency of land uses, land use intensities, and land use impacts as related to the environs of the subject property.

*Staff Comment: The proposal is an appropriate land use in the B-3 district.*

5. **Utilities and public services.** The use will be adequately served by, and will not impose an undue burden on, any of the improvements, facilities, utilities, or services provided by the City or any other public agency serving the subject property.

*Staff Comment: The property is currently served by public utilities.*

**Required Plan Commission conclusion:** Section 130-104(3)(f) of the Municipal Code requires the Plan Commission to determine whether the potential public benefits of the conditional use do or do not outweigh any and all potential adverse impacts. The proposed motion below states that benefits do in fact outweigh any and all potential adverse impacts.

**Staff recommended motion for Site Plan:** *The Plan Commission approves the Site Plan for two commercial buildings on parcel 6-27-958.091A1 (Tax ID 222 070001011), finding that the benefits of the use outweigh any potential adverse impacts, and that the proposed use is consistent with the required standards and criteria for issuance of a Site Plan Approval set forth in Section 130-104 of the Zoning Ordinance. The Site Plan is approved subject to the following conditions:*

- 1) *Curbing to be installed as depicted in red on the attached site plan.*
- 2) *Arborvitae are installed to screen the parking area between the residential building and*
- 3) *Applicant signs Amendment #1 to the Development Agreement by April 5<sup>th</sup>, 2023.*
- 4) *The business operator shall comply with all provisions in the city's zoning code, as may be amended, including conditional use regulations as per sections 130-408.*
- 5) *Any substantial changes to the site plan or expected uses shall require a review of the existing conditional use permits and will require the application, fee, review and issuance of a new conditional use permit.*
- 6) *The use shall not cause a public or private nuisance as defined by State law.*
- 7) *The site plan Amendment #1 are recorded with the Rock County Register of Deeds.*



Member  
 Wisconsin  
 System Interceptor

To Obtain Location of  
 Participants Underground  
 Facilities Before You  
 Dig in Wisconsin

CALL DIGGERS  
 HOTLINE  
 1-800-242-8511

Wis Statute 182.0175 (1974)  
 Requires Min. 3 Work Days  
 Notice Before You Excavate



**CONTACTS:**

**ARCHITECT:**  
 Destree Design Architects, Inc.  
 222 W. Washington Ave., Suite 310  
 Madison, WI 53703  
 608-268-1499  
 www.destreearchitects.com

**CIVIL:**  
 Combs & Associates  
 109 W. Milwaukee St.  
 Janesville, WI 53548  
 608-752-0575  
 www.combsurvey.com

**OWNER:**  
 Phillips Contracting, LLC  
 65 N. Union Rd.  
 Evansville, WI 53536  
 608-751-4025

**LANDSCAPE:**  
 Pleasant Prairie Green House  
 16907 W. County Road C  
 Evansville, WI 53536  
 608-882-0501

**LEGEND:**

- EASEMENT LINE
- SANITARY SEWER
- SANITARY SERVICE
- WATER MAIN
- WATER SERVICE
- STORM SEWER
- PROPERTY LINE
- FENCE LINE
- CONTOUR LINE
- EXISTING BUILDING LINE
- PROPOSED/FUTURE BUILDING LINE
- AERIAL UTILITY WIRE (S)
- TELEPHONE LINE
- GAS LINE
- ELECTRIC LINE
- PROPOSED GREEN SPACE
- PROPOSED OVERLAND FLOW DIRECTION
- UE UTILITY EASEMENT
- CB CATCH BASIN
- MEM ELECTRIC METER
- ET ELECTRIC TRANSFORMER
- GV GAS VALVE
- WT TELEPHONE BOX
- WV WATER VALVE
- FD FIRE HYDRANT
- LP LIGHT POLE (LP)
- PP POWER POLE
- EXISTING SPOT ELEVATION

**PHASE ONE NOTES:**  
 Site changes associated with the first 2 buildings must be completed within 1 year of site plan approval.

**PHASE TWO NOTES:**  
 Phase 2 site changes must be completed within 2 years of site plan approval. If a site plan is approved for a future 3rd building, then these changes may be delayed, and constructed as part of the approved building 3 plan.

STORMWATER  
 MANAGEMENT  
 AREA

EXISTING  
 STORMWATER  
 MANAGEMENT  
 AREA

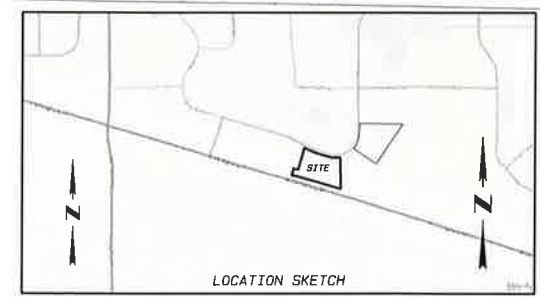

- INDEX OF SHEETS**
1. COVER SHEET/DIMENSION PLAN
  2. DEMOLITION PLAN
  3. GENERAL NOTES/ SANITARY NOTES & DETAILS
  4. WATER DETAILS
  5. STORM NOTES/ GENERAL DETAILS
  6. UTILITY PLAN
  7. OVERALL SITE GRADING PLAN
  8. NORTH GRADING PLAN
  9. SOUTH GRADING PLAN
  10. WEST GRADING PLAN
  11. EROSION CONTROL & SEEDING PLAN
  12. ECP NOTES & DETAILS

**SITE DATA (EXCLUDING FUTURE IMPROVEMENTS):**  
 CURRENT GREENSPACE: 60,640 SF (64.7%)  
 CURRENT IMPERVIOUS AREA: 33,014 SF (32.3%)  
 TOTAL LOT AREA: 93,654 SF



**AMENDED SITE PLAN  
 FOR  
 MORNING RIDGE RETAIL CENTER**

LOT 2 OF A CERTIFIED SURVEY MAP RECORDED IN VOLUME 34, PAGES 345 THRU 349 OF CERTIFIED SURVEY MAPS OF ROCK COUNTY, WISCONSIN AS DOCUMENT NO. 1935946 AND LOCATED IN THE NW 1/4 OF THE SW 1/4 OF SECTION 25, T.4N., R., 10E. OF THE 4TH P.M., CITY OF EVANSVILLE, ROCK COUNTY, WISCONSIN.

<b>Combs &amp; Associates</b>	LAND SURVEYING	DATE: 08/12/22	REVISIONS
	LAND PLANNING	BY: AFG	10/24/20 City revisions AFG
	CIVIL ENGINEERING	APPROVED:	11/06/22 3rd Bldg AFG
109 N. Milwaukee St. Janesville, WI 53548	tel: 608 752-0575 fax: 608 752-0534	PROJECT NO. 122-294	02/01/23 City revisions AFG

FOR AGENCY REVIEW,  
 NOT FOR CONSTRUCTION

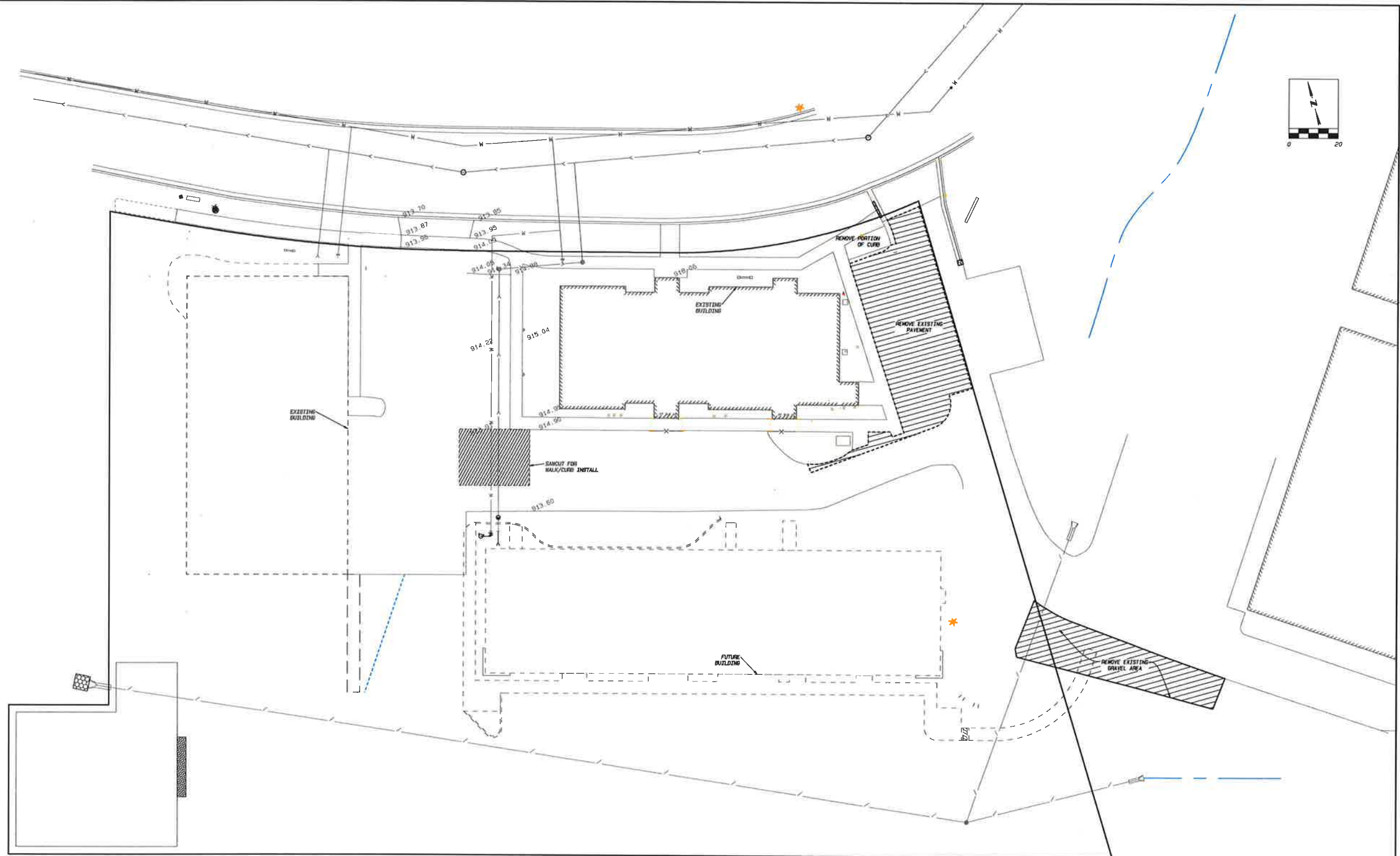
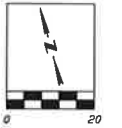

 109 N. Milwaukee St. Janesville, WI 53548	• LAND SURVEYING	DATE	08/12/22	REVISIONS
	• LAND PLANNING	BY	AFG	10/24/22 City revisions AFG
	• CIVIL ENGINEERING	APPROVED		11/28/22 3rd B10g AFG
				02/01/23 City revisions AFG
		PROJECT NO.	122-294	



**GENERAL NOTES:**

All roadway construction shall be in conformance with the Typical Finished Sections shown, and in conformance with the City of Evansville "Construction Standards and Policies, latest edition, and with the State of Wisconsin Department of Transportation "Standard Specifications for Road and Bridge Construction, latest edition" unless otherwise indicated on the plans.

All sanitary sewer (and services), water (and services) and storm sewer shall be constructed in conformance with the City of Evansville "Construction Standards and Policies, latest edition, and the Standard Specifications for Sewer and Water Construction in Wisconsin, latest edition.

Contractor shall backfill all storm sewer, sanitary sewer and laterals, water main and services in structural areas using granular backfill per detail on plans. Materials and compaction to conform with the City of Evansville "Construction Standards and Policies, latest edition.

Permits shall be obtained for any street openings.

All water piping, including services, shall be constructed a minimum of 7.0 feet below finished ground.

Topsoil shall be stripped from the roadbed/paved areas prior to any excavation and shall be stockpiled as directed by the Owner. It is the contractor's responsibility to verify the depth of existing topsoil prior to his bid or quote. Contractor shall provide topsoil from off site, if required, to provide a minimum 4 inch thick topsoil layer in vegetated areas.

The contractor shall clear, grub, and dispose of all brush, stumps, trees, etc., within the construction limits of the site. Contractor shall remove those materials from the work site and dispose of them at the contractor's option and in conformance with State and local regulations.

The subgrade shall be thoroughly compacted to the placement of the aggregate base course in conformance with City of Evansville "Construction Standards and Policies, latest edition, crown shall conform to pavement crown indicated.

Unclassified excavation shall consist of all excavated material necessary to provide a subbase to the lines and grade shown on the plans.

Seeding shall be in conformance with Section 630 of the "Standard Specifications for Road and Bridge Construction", latest edition. Seeding shall meet seed mixture no. 10. All seeded areas shall be mulched and fertilized at a rate of 1.5 pounds per 1000 square feet.

The Contractor shall furnish and set line and grade stakes necessary for construction.

Contractor shall verify location of any existing utilities prior to excavation. Where the roadway/pavement construction conflicts with existing utilities, contractor shall contact owner of said utility to relocate/deepen the utility in question. Call Diggers Hotline before digging.

Rip-rap shall conform to Wisconsin Department of Transportation "Standard Specifications for Road and Bridge Construction", Section 606.

All removal and replacement of existing pavements, sidewalks, and curbs shall be constructed in conformance with the City of Evansville, "Construction Standard and Policies, latest edition.

Contractor shall provide field quality testing as specified in the City of Evansville "Construction Standards and Policies, latest edition.

Where conflicts occur between the City of Evansville "Construction Standards and Policies, latest edition, and referenced specifications or details, City of Evansville "Construction Standards and Policies, latest edition, shall take precedence.

The asphaltic pavement shall be constructed to the minimum depths shown on the typical cross-sections. Pavement to be placed in two lifts, with binder and surface courses. Asphaltic pavement shall conform to the Standard Specifications for Asphaltic Concrete Pavement, Type LV. Surface course shall be grade 3 and binder course shall be grade 4. The top lift shall have a maximum particle size of 3/4 inch. Surface course to be placed 12 months after binder course.

Contractor shall verify location and dimensions of Type 2 sidewalk ramps with City Engineer, prior to construction.

Contractor shall ensure drive approaches shall be in accordance with City of Evansville specifications.

Maximum pavement slope for handicapped stalls shall not exceed 2% in any direction.

Maximum pavement slope for handicapped routes shall not exceed 5% in any direction (2% max cross slope).

Contractor shall provide unit prices to owner at time of bid for removal and replacement of unsuitable material under structures and pavement as approved by owner.

Sidewalk replacement must be within 2 weeks of removal. If contractor needs to close the sidewalk, a temporary closure plan needs to be submitted to the City for review.

Contractor shall notify City of Evansville 48 hours prior to start of construction.

**SANITARY NOTES:**

SANITARY SEWER MAIN AND LATERALS SHALL BE ASTM D3034, PSM 30R-35 PVC PIPE WITH ASTM F477 ELASTOMERIC JOINTS. SOLVENT WELD JOINTS NOT PERMITTED.

SANITARY SEWER SERVICE LATERALS SHALL BE ASTM D 1785 PVC PIPE SCHEDULE 40 WITH ASTM F477 ELASTOMERIC JOINTS. SOLVENT WELD JOINTS NOT PERMITTED. FITTINGS TO CONFORM WITH ASTM D 2466.

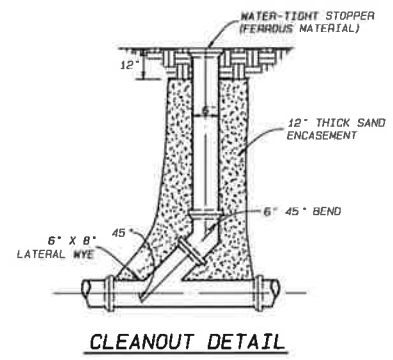
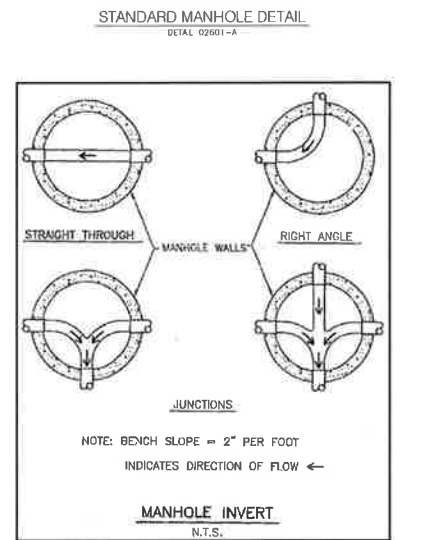
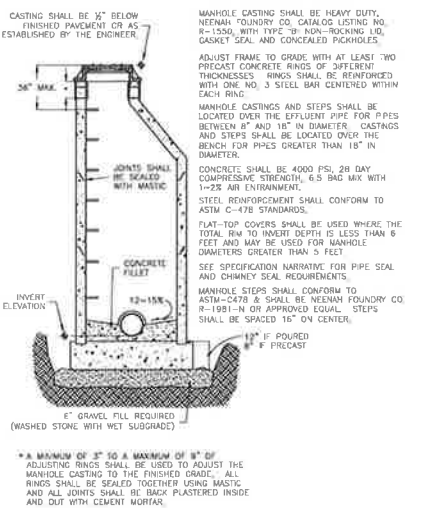

**15C2 sheet b: Barricades and Signs for Mainline Closures**

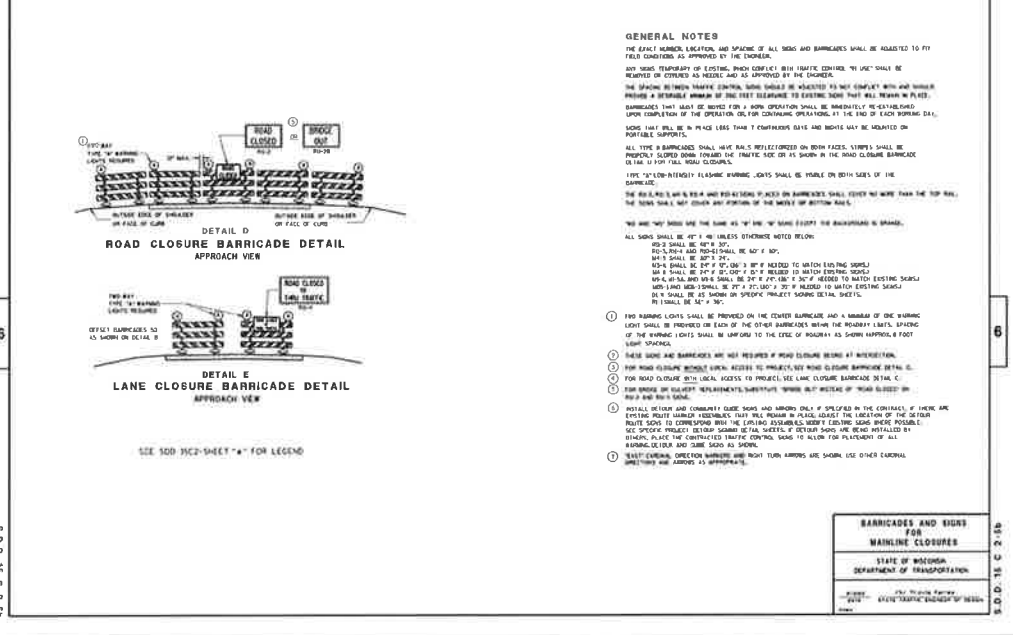

**GENERAL NOTES**

THE EXACT NUMBER, LOCATION, AND SPACING OF ALL SIGNS AND BARRICADES SHALL BE REQUESTED TO FIT FIELD CONDITIONS AS APPROVED BY THE ENGINEER.

ANY SIGN REQUIREMENT OF EXISTING SIGNS WHICH ARE NOT INDICATED ON THESE PLANS SHALL BE REQUESTED BY THE CONTRACTOR.

THE SIGNING AND BARRICADE PLAN, SIGN SCHEDULES BE WEATHERED TO NOT EXHAUSTED WITH AND NUMBER PROVIDED A SUFFICIENT NUMBER OF THE FIRST REQUIREMENT TO EXISTING SIGNS THAT WILL REMAIN IN PLACE.

BARRICADES THAT MUST BE REMOVED FOR A NEW OPERATION SHALL BE INDICATED BY KEYHOLE AND UPON COMPLETION OF THE OPERATION THE CONTRACTOR OPERATIONS AT THE END OF EACH WORKING DAY.

SIGNS SHALL BE IN PLACE UNTIL THE CONTRACTOR SAYS AND MUST BE IN PLACE ON ALL PORTABLE SUPPORTS.

ALL SIGNS SHALL BE PLACED ON BOTH SIDES OF THE ROADWAY. SIGNS SHALL BE PLACED ON BOTH SIDES OF THE ROADWAY. SIGNS SHALL BE PLACED ON BOTH SIDES OF THE ROADWAY. SIGNS SHALL BE PLACED ON BOTH SIDES OF THE ROADWAY.

ALL SIGNS SHALL BE 4\"/>

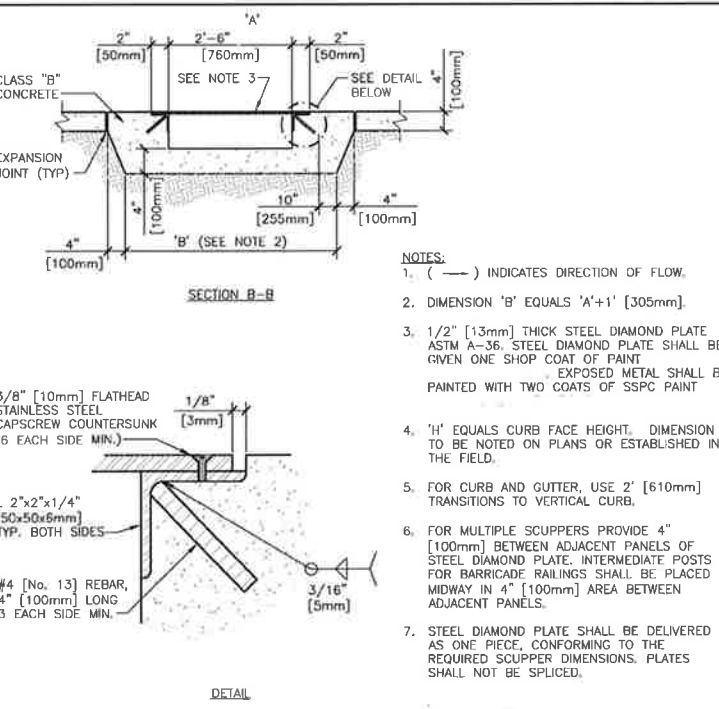
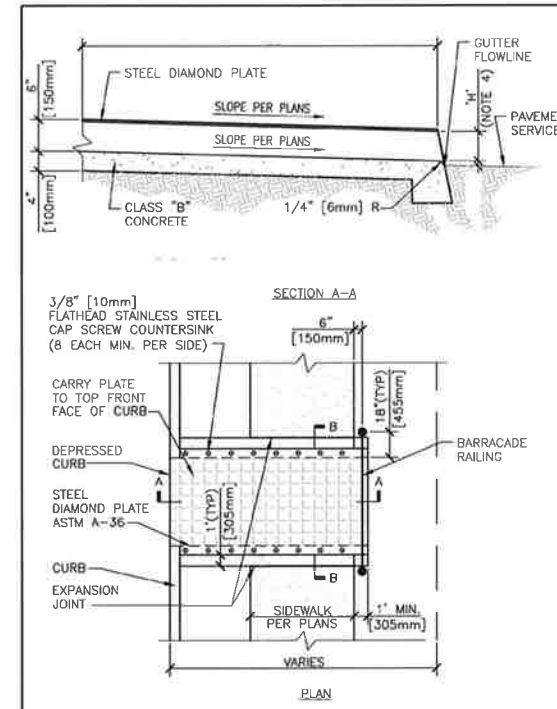
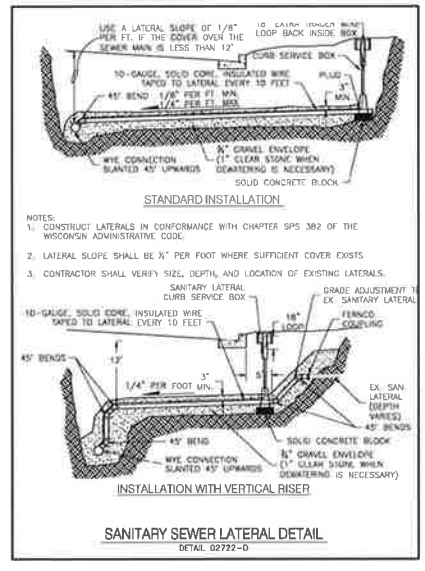
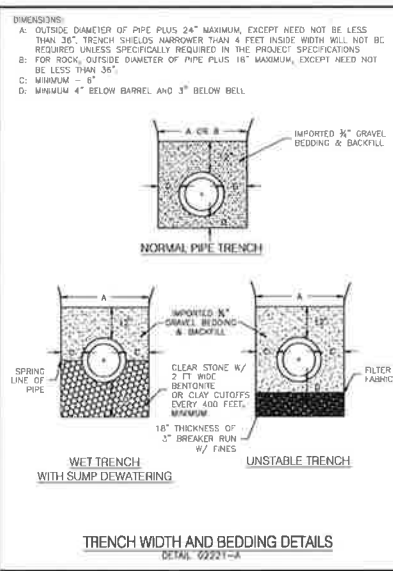

**Combs & Associates**

DATE	08/12/22
REVISIONS	10/24/22 City revisions AFG 11/28/22 3rd Bldg AFG 02/01/23 City revisions AFG
BY	AFG
APPROVED	
PROJECT NO.	122-294
109 N. Milwaukee St. Janesville, WI 53548	TEL: 608 752-0575 FAX: 608 752-0534

**DIMENSIONS:**  
 A: OUTSIDE DIAMETER OF PIPE PLUS 24" MAXIMUM, EXCEPT NEED NOT BE LESS THAN 36". TRENCH SHIELDS NARROWER THAN 4 FEET INSIDE WIDTH WILL NOT BE REQUIRED UNLESS SPECIFICALLY REQUIRED IN THE PROJECT SPECIFICATIONS.  
 B: FOR ROCK, OUTSIDE DIAMETER OF PIPE PLUS 18" MAXIMUM, EXCEPT NEED NOT BE LESS THAN 36".  
 C: MINIMUM - 6"  
 D: MINIMUM 4" BELOW BARREL AND 3" BELOW BELL

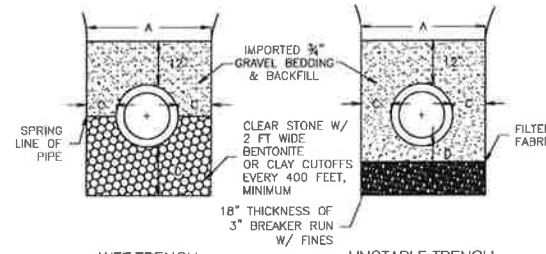
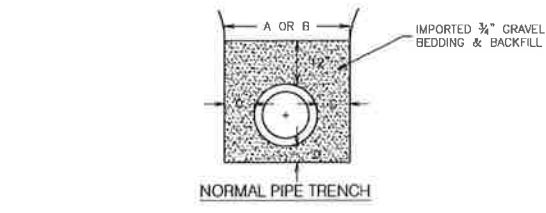

**TRENCH WIDTH AND BEDDING DETAILS**  
 DETAIL 02221-A

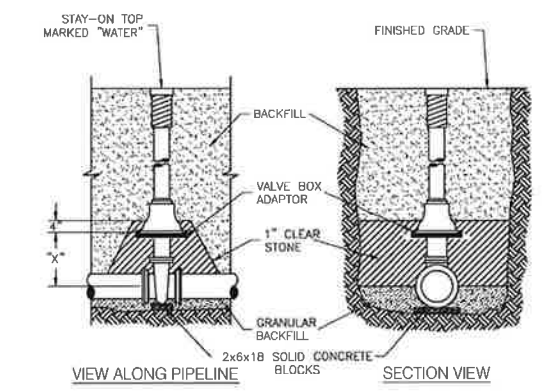

PIPE DIA., INCHES	6	8	10	12	14	16
"X" DIMENSION, INCHES	12	13	17	21	25	30

**NOTES:**  
 - VALVES SHALL BE SECURED WITH RODDING OR MEGALUGS TO THE NEAREST "TEE" FITTING OR TO THE FIRST JOINT CONNECTING A FULL SECTION OF WATER MAIN PIPE. SEE RODDING DETAIL 02701-C

**STANDARD VALVE BOX SETTING**  
 DETAIL 02701-D

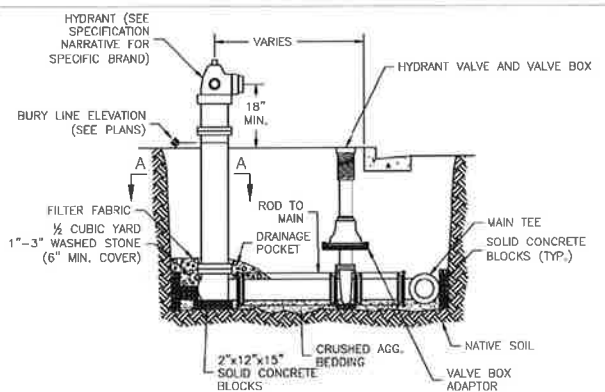

**NOTES:**  
 - THE HYDRANT AND HYDRANT VALVE SHALL BE CONNECTED TO THE MAIN TEE BY RODDING IN ACCORDANCE WITH DETAIL 02701-C, OR BY MEGA LUGS.  
 - THE DISTANCE BETWEEN THE HYDRANT AND THE MAIN WILL VARY. OFFSET DISTANCES ARE MARKED ON THE PLANS.  
 - WHERE THE HYDRANT IS INSTALLED AT THE HIGH POINT OF THE WATER MAIN ON MAINS 10 INCHES IN DIAMETER AND LARGER THE CONTRACTOR SHALL TIP THE MAIN TEE UPWARDS 45 DEGREES AND USE A 45 DEGREE FITTING TO ALLOW AIR TO ESCAPE FROM THE MAIN.

**STANDARD HYDRANT SETTING**  
 DETAIL NO. 02701-A

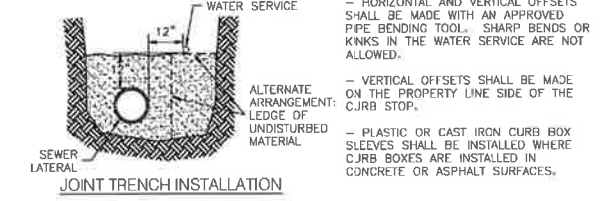
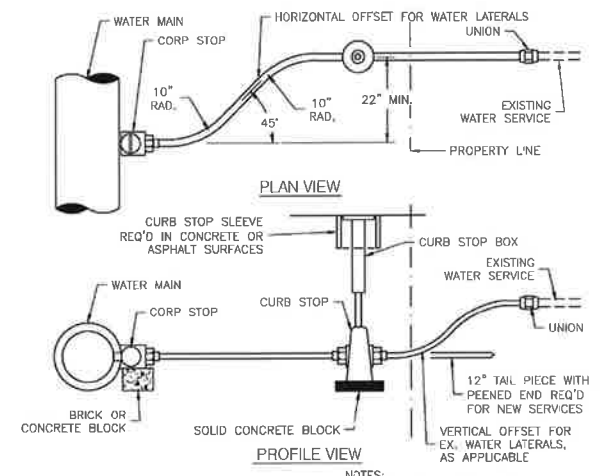

**WATER SERVICE INSTALLATION DETAIL**  
 DETAIL 02701-F

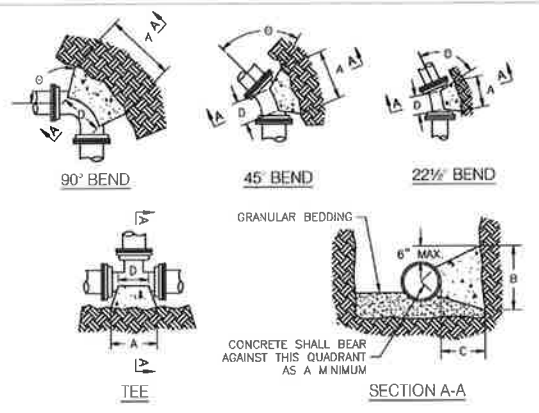

DIMENSION "D" SHALL BE AS LARGE AS POSSIBLE, BUT THE CONCRETE SHALL NOT INTERFERE WITH THE MECHANICAL JOINTS.  
 DIMENSION "C" SHALL BE AT LEAST 6 INCHES, AND LARGE ENOUGH TO MAKE THE "θ" ANGLE EQUAL TO OR GREATER THAN 45 DEGREES WITH THE DIMENSION "A" AS SHOWN ON THE TABLE, OR GREATER, AND WITH DIMENSION "D" AS LARGE AS POSSIBLE.

CONCRETE SHALL BE CLASS "CC", SEE SECTION 03301

PIPE SIZE	BUTTRISS DIMENSIONS			
	TEES	22 1/2° BEND	45° BEND	90° BEND
6	1'-3"	1'-0"	1'-0"	1'-0"
8	1'-6"	1'-4"	1'-0"	1'-4"
10/12	2'-3"	2'-0"	1'-4"	1'-10"
14/16	3'-2"	2'-6"	1'-10"	2'-4"
18/20	4'-0"	3'-0"	2'-0"	3'-3"
22/24	5'-3"	4'-2"	2'-4"	3'-3"
30	6'-3"	5'-6"	3'-0"	4'-8"

\* FOR TEE THIS WILL BE THE BRANCH PIPE

**BUTTRISS DETAILS**  
 DETAIL NO. 02701-B

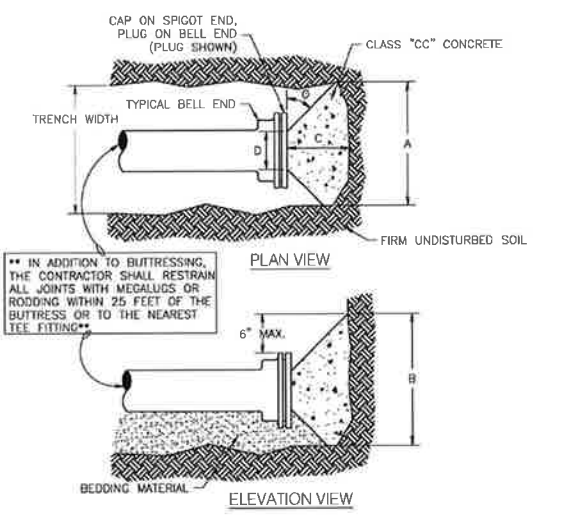

DIA.	BUTTRISS DIMENSIONS			
	A	B	C	D
6"	1'-3"	1'-0"		
8"	1'-8"	1'-6"		
10"	2'-0"	1'-8"		
12"	2'-5"	1'-10"		
16"	3'-4"	2'-4"		
20"	4'-3"	2'-10"		
24"	5'-2"	3'-4"		
30"	6'-9"	4'-0"		

**BUTTRISS DETAIL FOR DEAD ENDS**  
 DETAIL 02701-H

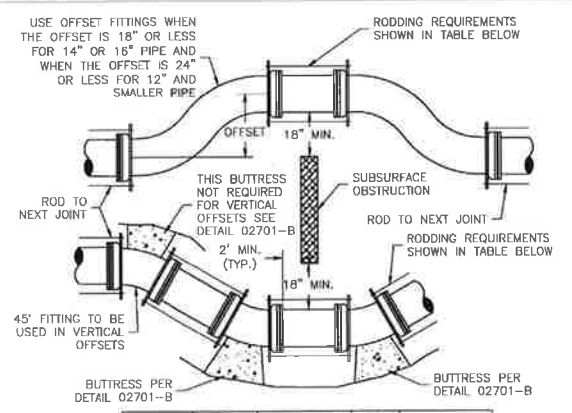

NOMINAL PIPE SIZE	RODS NO.	RODS DIA.	STRAP SIZE	BOLT DIA.	WASHER SIZE
6	3	1/2"	1/2" x 2"	1/2"	1/2" x 3 x 5
8	4	3/4"	1/2" x 2"	3/4"	1/2" x 3 x 5
10	4	1/2"	1/2" x 2 1/2"	1"	1/2" x 3 x 5
12	4	3/4"	1/2" x 2 1/2"	1"	1/2" x 3 x 5
14	4	1/2"	1/2" x 2 1/2"	1"	1/2" x 3 x 5

**NOTES:**  
 - RODS AND WASHERS TO BE ASTM A-575 MERCHANT QUALITY 0.17-0.24 CARBON. NUTS TO BE AMERICAN STANDARD HEAVY, NOT PRESSED.  
 - TIE RODS, BOLTS, NUTS, BANDS AND WASHERS TO BE FURNISHED AND ASSEMBLED BY THE CONTRACTOR.  
 - ALL STEEL MATERIAL TO BE THOROUGHLY COATED WITH KOPPERS NO. 50 BITUMASTIC.  
 - OFFSET FITTINGS REQUIRE CONTINUOUS RODDING IN ALL POSITIONS.  
 - VERTICAL OFFSETS SHALL NOT CREATE A HIGH POINT IN THE WATER MAIN. VERTICAL OFFSETS REQUIRE THE SAME RODDING AND BUTTRISSING AS SHOWN ABOVE.  
 - MEGALUG RESTRAINTS MAY BE USED IN LIEU OF RODDING.

**OFFSET AND RODDING DETAILS**  
 DETAIL 02701-C

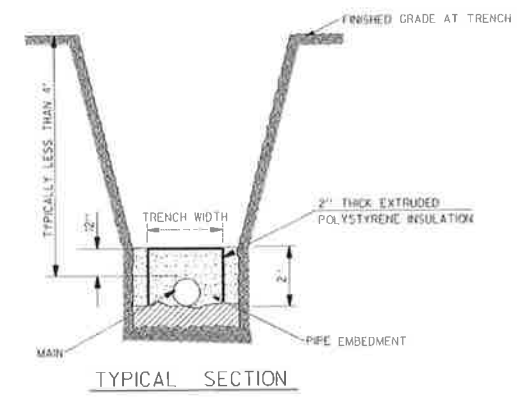

**PIPE INSULATION DETAIL**

	<b>LAND SURVEYING</b> DATE: 08/12/22	REVISIONS 10/24/22 City revisions AFG 11/28/22 3rd Bldg AFG 02/01/23 City revisions AFG
	<b>LAND PLANNING</b> BY: AFG	
	<b>CIVIL ENGINEERING</b> APPROVED:	
109 W. Milwaukee St. Janesville, WI 53408 tel: 608 752-0575 fax: 608 752-0534	PROJECT NO. 122-294	



**STORM NOTES:**

- STORM MANHOLE COVERS SHALL BE NEENAH R-1726-A, SOLID LTD. UNLESS OTHERWISE NOTED.
- OPEN GRATE MANHOLE COVERS SHALL BE NEENAH MODEL NO. R-2556.
- STORM MANHOLES AND INLETS SHALL BE PRECAST CONSTRUCTION.
- CORRUGATED POLYETHYLENE STORM SENER PIPE (CPE) SHALL CONFORM TO WISCONSIN DOT STANDARD SPECIFICATIONS SECTION 530.
- CONTRACTOR SHALL POUR A CONCRETE COLLAR AROUND THE JOINT BETWEEN CPE STORM SENER AND RCP ENDWALLS.
- REINFORCED CONCRETE PIPE SHALL CONFORM TO ASTM C76 WITH BELL AND SPIGOT JOINTS CONFORMING TO ASTM C443 WITH FLAT RUBBER GASKETS, CLASS OF STORM SENER PIPE SHALL BE:
  - CLASS 3 FOR 15" DIAMETER AND LARGER.
  - CLASS 5 FOR 12" DIAMETER.

**8F1: Apron Endwalls for Culvert Pipe**

METAL APRON ENDWALLS											
NO.	APPROX. QTY.	APPROX. WEIGHT	APPROX. VOLUME	APPROX. AREA	APPROX. PERIMETER	APPROX. LENGTH	APPROX. WIDTH	APPROX. HEIGHT	APPROX. THICKNESS	APPROX. DIAMETER	APPROX. RADIUS
1	1	100	10	100	100	100	100	100	100	100	100
2	1	100	10	100	100	100	100	100	100	100	100
3	1	100	10	100	100	100	100	100	100	100	100
4	1	100	10	100	100	100	100	100	100	100	100
5	1	100	10	100	100	100	100	100	100	100	100
6	1	100	10	100	100	100	100	100	100	100	100
7	1	100	10	100	100	100	100	100	100	100	100
8	1	100	10	100	100	100	100	100	100	100	100
9	1	100	10	100	100	100	100	100	100	100	100
10	1	100	10	100	100	100	100	100	100	100	100
11	1	100	10	100	100	100	100	100	100	100	100
12	1	100	10	100	100	100	100	100	100	100	100
13	1	100	10	100	100	100	100	100	100	100	100
14	1	100	10	100	100	100	100	100	100	100	100
15	1	100	10	100	100	100	100	100	100	100	100
16	1	100	10	100	100	100	100	100	100	100	100
17	1	100	10	100	100	100	100	100	100	100	100
18	1	100	10	100	100	100	100	100	100	100	100
19	1	100	10	100	100	100	100	100	100	100	100
20	1	100	10	100	100	100	100	100	100	100	100
21	1	100	10	100	100	100	100	100	100	100	100
22	1	100	10	100	100	100	100	100	100	100	100
23	1	100	10	100	100	100	100	100	100	100	100
24	1	100	10	100	100	100	100	100	100	100	100
25	1	100	10	100	100	100	100	100	100	100	100
26	1	100	10	100	100	100	100	100	100	100	100
27	1	100	10	100	100	100	100	100	100	100	100
28	1	100	10	100	100	100	100	100	100	100	100
29	1	100	10	100	100	100	100	100	100	100	100
30	1	100	10	100	100	100	100	100	100	100	100
31	1	100	10	100	100	100	100	100	100	100	100
32	1	100	10	100	100	100	100	100	100	100	100
33	1	100	10	100	100	100	100	100	100	100	100
34	1	100	10	100	100	100	100	100	100	100	100
35	1	100	10	100	100	100	100	100	100	100	100
36	1	100	10	100	100	100	100	100	100	100	100
37	1	100	10	100	100	100	100	100	100	100	100
38	1	100	10	100	100	100	100	100	100	100	100
39	1	100	10	100	100	100	100	100	100	100	100
40	1	100	10	100	100	100	100	100	100	100	100
41	1	100	10	100	100	100	100	100	100	100	100
42	1	100	10	100	100	100	100	100	100	100	100
43	1	100	10	100	100	100	100	100	100	100	100
44	1	100	10	100	100	100	100	100	100	100	100
45	1	100	10	100	100	100	100	100	100	100	100
46	1	100	10	100	100	100	100	100	100	100	100
47	1	100	10	100	100	100	100	100	100	100	100
48	1	100	10	100	100	100	100	100	100	100	100
49	1	100	10	100	100	100	100	100	100	100	100
50	1	100	10	100	100	100	100	100	100	100	100

**ALTERNATE FOR TYPE I CONNECTION END SECTION CONNECTOR STRAP**

SECTION A-A

GENERAL NOTES

APRON ENDWALLS FOR CULVERT PIPE

STATE OF WISCONSIN  
DEPARTMENT OF TRANSPORTATION

CONNECTION DETAILS

**CAR ACCESSIBLE HANDICAP PARKING SIGN DETAIL**

**VAN ACCESSIBLE HANDICAP PARKING SIGN DETAIL**

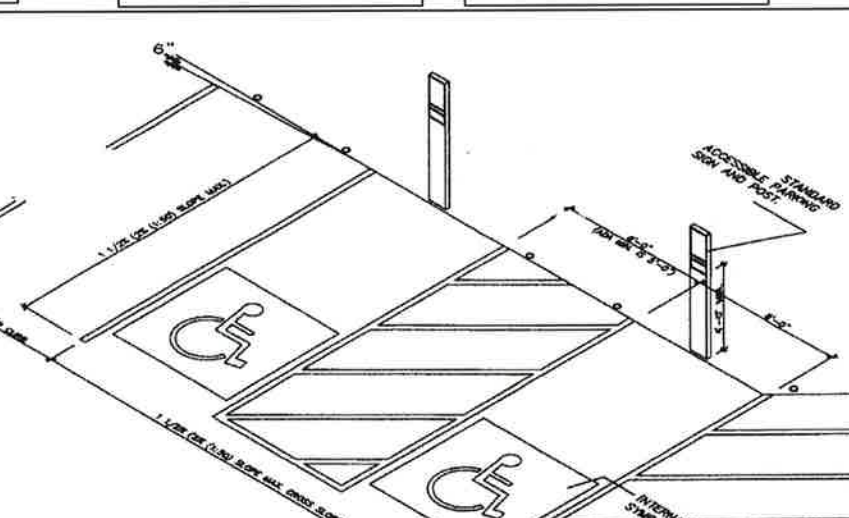

NOTES:

EACH ACCESSIBLE PARKING SPACE IS TO BE A MINIMUM OF 8 FEET WIDE AND HAVE A 96" MINIMUM ACCESS AISLE FOR VANS OR 80" ACCESS AISLE FOR CARS ADJACENT TO THE SPACE. THE ACCESS AISLE MAY BE ON EITHER THE DRIVER'S SIDE OR THE PASSENGER'S SIDE OF THE ACCESSIBLE SPACE. THIS APPLIES TO 45, 60, AND 90° PARKING.

ACCESSIBLE PARKING SPACES ARE TO BE LOCATED AS CLOSE TO THE STORE ENTRANCE AS POSSIBLE AND SHALL BE IDENTIFIED WITH A SIGN.

ACCESSIBLE PARKING SPACES AND ACCESS AISLES SHALL BE LEVEL WITH A SLOPE OF 1/4" PER FT. (MAXIMUM) / EXAMPLE: 1.92 INCHES MAX. VERTICAL IN 8 FEET HORIZONTAL OR 1:80 IN ALL DIRECTIONS. THIS INCLUDES BOTH "RUNNING SLOPES" AND "CROSS SLOPES."

THE ACCESS AISLE SHALL BE DESIGNATED WITH HIGH QUALITY YELLOW DIAGONAL SURFACE PAINT STRIPING.

ADA ALLOWS TWO PARKING SPACES TO SHARE AN ACCESS AISLE.

**TRENCH WIDTH AND BEDDING DETAILS**  
DETAIL 02221-A

**RECTANGULAR CURB INLET DETAIL**  
DETAIL 02721-A

**STORM SEWER MANHOLE/MANHOLE INLET/ MANHOLE-TYPE CURB INLET DETAIL**  
DETAIL 02721-F

**18" SPILL CURB**

**18" CARRY CURB**

**18" (MOUNTABLE) SPILL CURB**

**18" (MOUNTABLE) CARRY CURB**

**TYPICAL RAISED SIDEWALK**  
N.T.S.

**CONCRETE PAVEMENT**

**BITUMINOUS PAVEMENT**

<b>Combs &amp; Associates</b>	DATE	08/12/22	REVISIONS
	LAND SURVEYING	BY	10/24/22 City revision AFG
	LAND PLANNING	AFG	11/28/22 3rd 0190 AFG
CIVIL ENGINEERING	APPROVED		02/01/23 City revision AFG
PROJECT NO.	122-294		



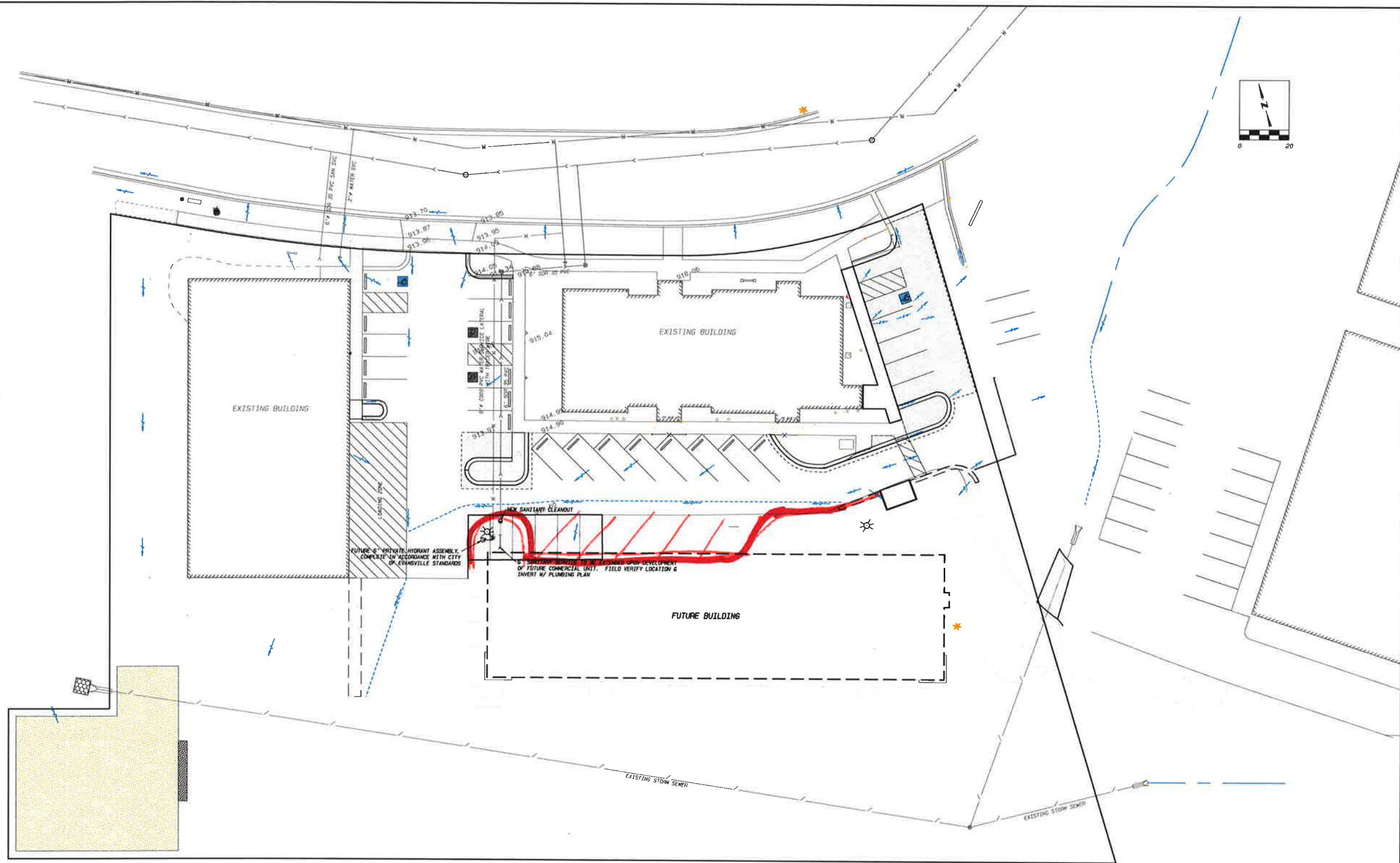

EXISTING SANITARY CLEANOUT

FUTURE 6" PRIVATE HYDRANT ASSEMBLY, COMPLETE IN ACCORDANCE WITH CITY OF EVANSVILLE STANDARDS

BY CONTRACTOR TO BE DETERMINED UPON DEVELOPMENT OF FUTURE COMMERCIAL UNIT. FIELD VERIFY LOCATION & INVERT W/ PLUMBING PLAN

	• LAND SURVEYING	DATE	08/12/22	REVISIONS
	• LAND PLANNING	BY	AFG	10/24/22 City revisions AFG
	• CIVIL ENGINEERING	APPROVED		11/28/22 3rd Bidg AFG
109 N. Milwaukee St. Evansville, IN 47540		TEL: 808 752-0525 FAX: 808 752-0534	PROJECT NO. 122-294	02/01/23 City revisions AFG

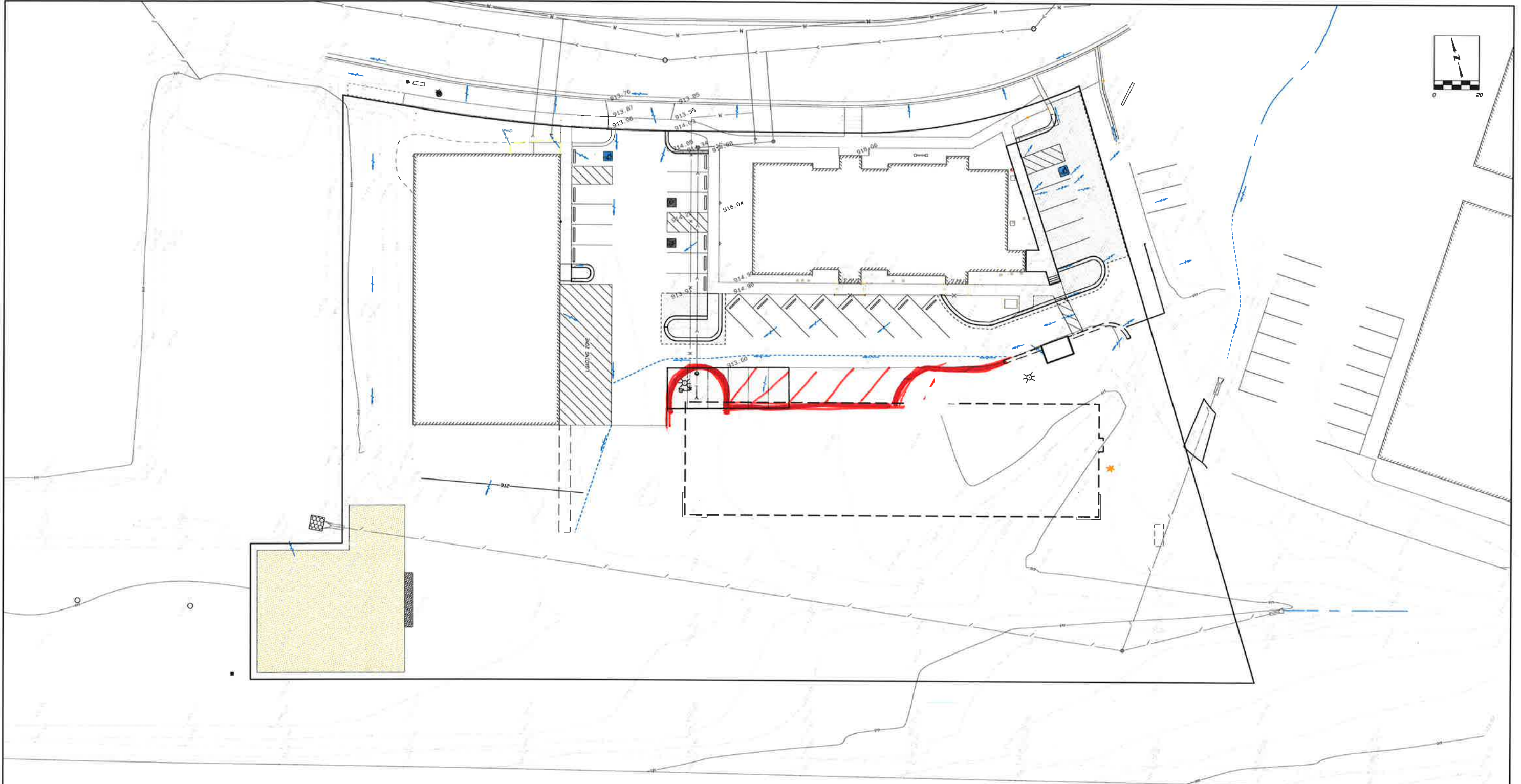

	• LAND SURVEYING	DATE	08/12/22	REVISION
	• LAND PLANNING	BY	AFG	10/24/22 City revisions AFG
	• CIVIL ENGINEERING	APPROVED		11/28/22 3rd Bidg AFG
				02/01/23 City revisions AFG
109 N. Milwaukee St. Johannesburg, MT 59548	tel: 608 752-0575 fax: 608 752-0534	PROJECT NO.	122-294	



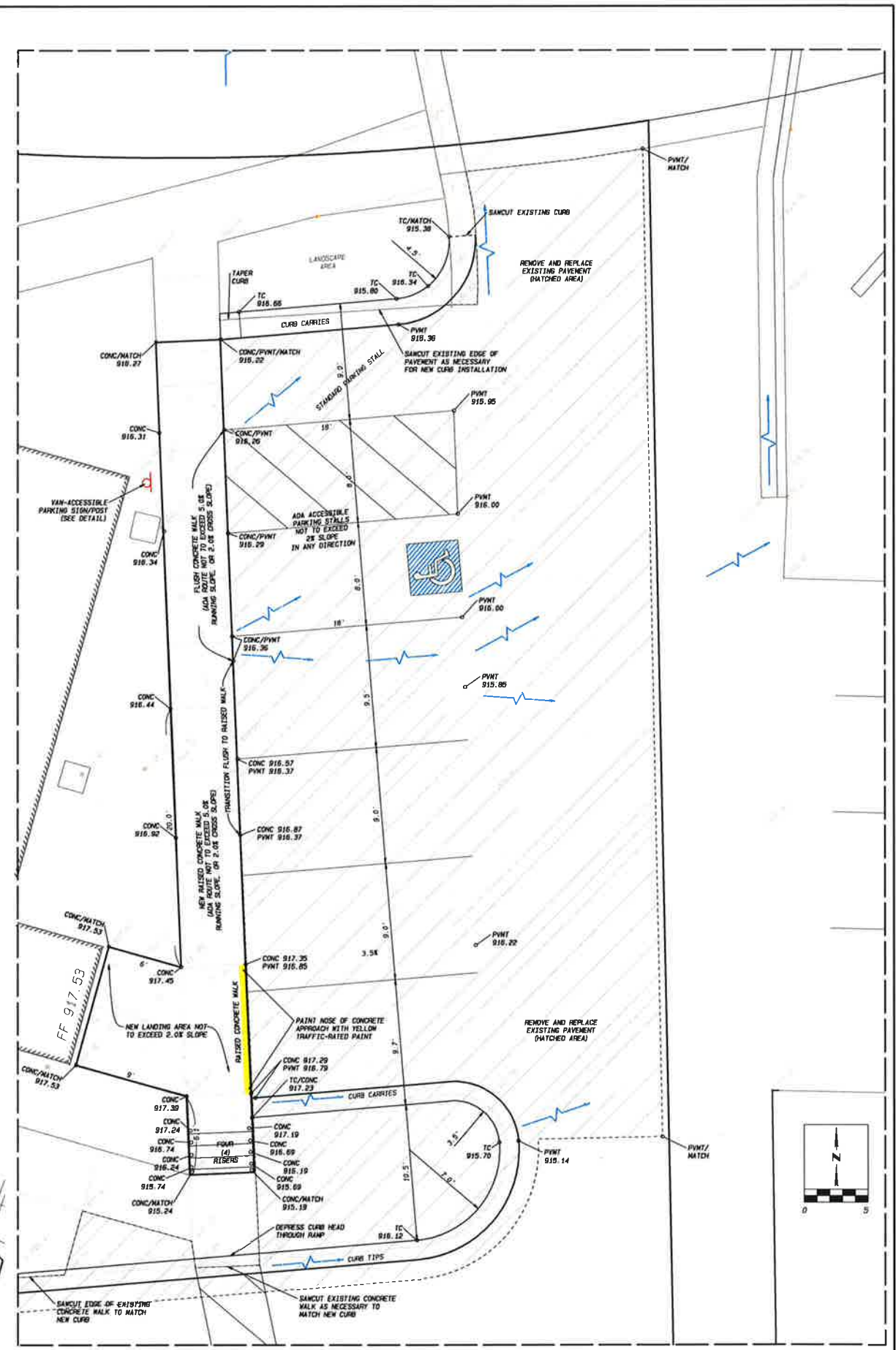
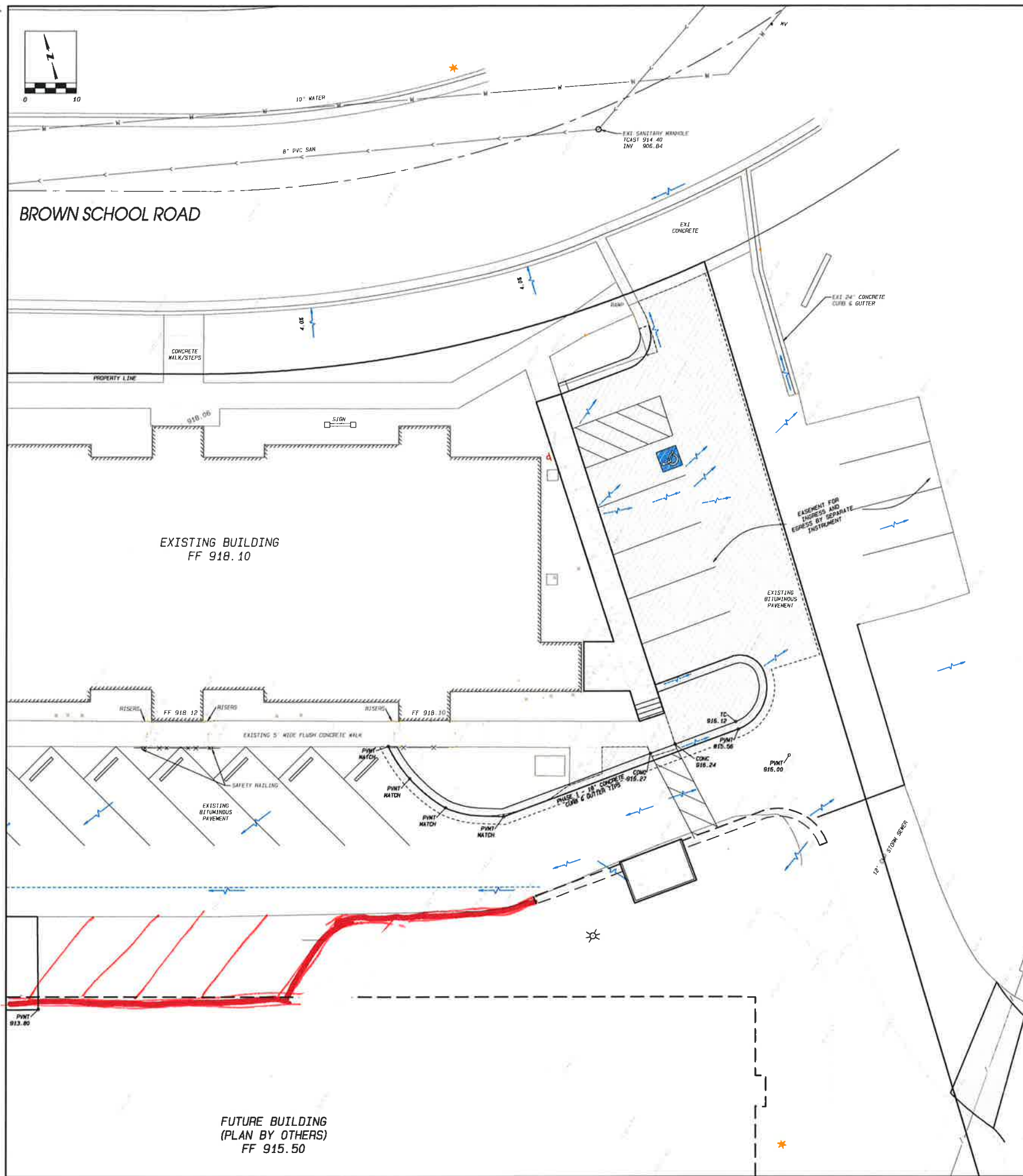

**EAST HANDICAP AREA DETAIL**

	• LAND SURVEYING	DATE: 08/12/22	REVISION:
	• LAND PLANNING	BY: AFG	10/24/22 City revisions AFG
	• CIVIL ENGINEERING	APPROVED:	11/09/22 3rd 0169 AFG
100 W. Milwaukee St. Janesville, WI 53548	Tel: 608 752-0575 Fax: 608 752-0534	PROJECT NO: <b>122-294</b>	02/01/23 City revisions AFG

**(NORTH) SITE GRADING PLAN**



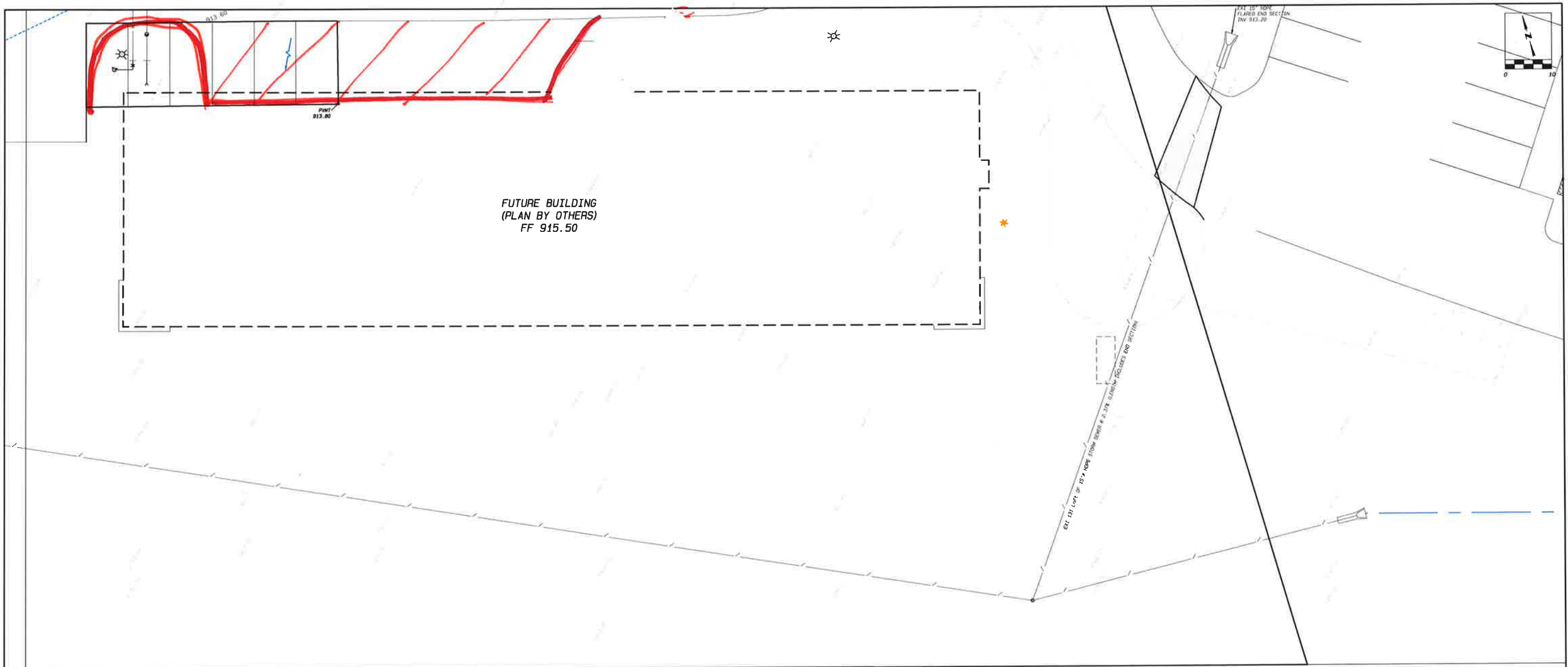

FUTURE BUILDING  
(PLAN BY OTHERS)  
FF 915.50



	<ul style="list-style-type: none"> <li>• LAND SURVEYING</li> <li>• LAND PLANNING</li> <li>• CIVIL ENGINEERING</li> </ul>	DATE <b>08/12/22</b>	REVISIONS 10/24/22 City revisions AFG 11/28/22 3rd Rtg AFG 02/01/23 City revisions AFG
	APPROVED <b>AFG</b>	PROJECT NO. <b>122-294</b>	
	100 N. Milwaukee St. Janesville, WI 53548 Tel: 608 752-0575 Fax: 608 752-0534		

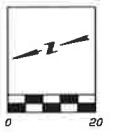
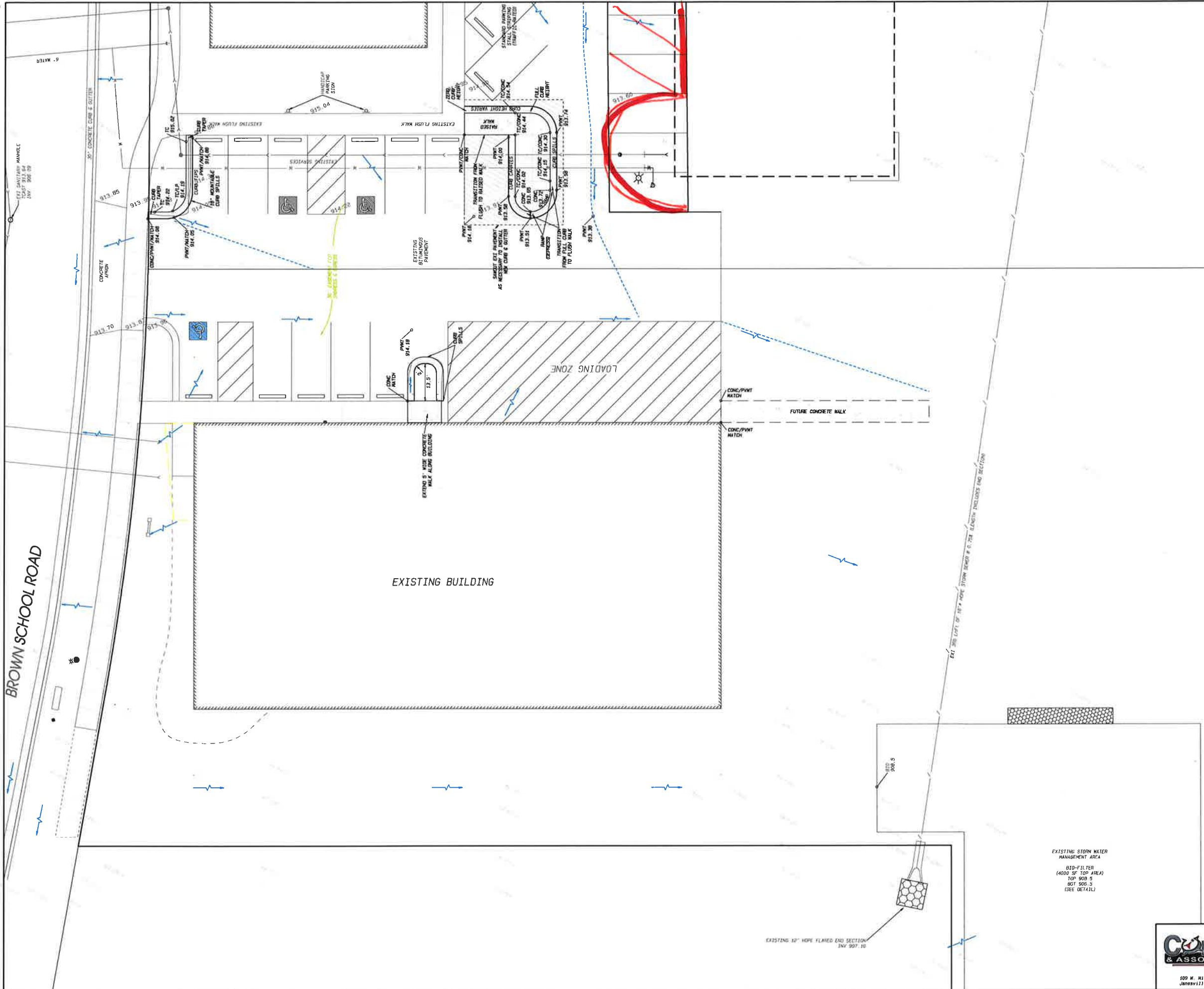

US HWY 14

	<ul style="list-style-type: none"> <li>• LAND SURVEYING</li> <li>• LAND PLANNING</li> <li>• CIVIL ENGINEERING</li> </ul>	DATE <b>08/12/22</b>	REVISIONS 10/24/22 City revisions AFG 11/28/22 3rd Bldg AFG 03/01/23 City revisions AFG
		BY <b>AFG</b>	
		APPROVED  	
PROJECT NO. <b>122-294</b>			

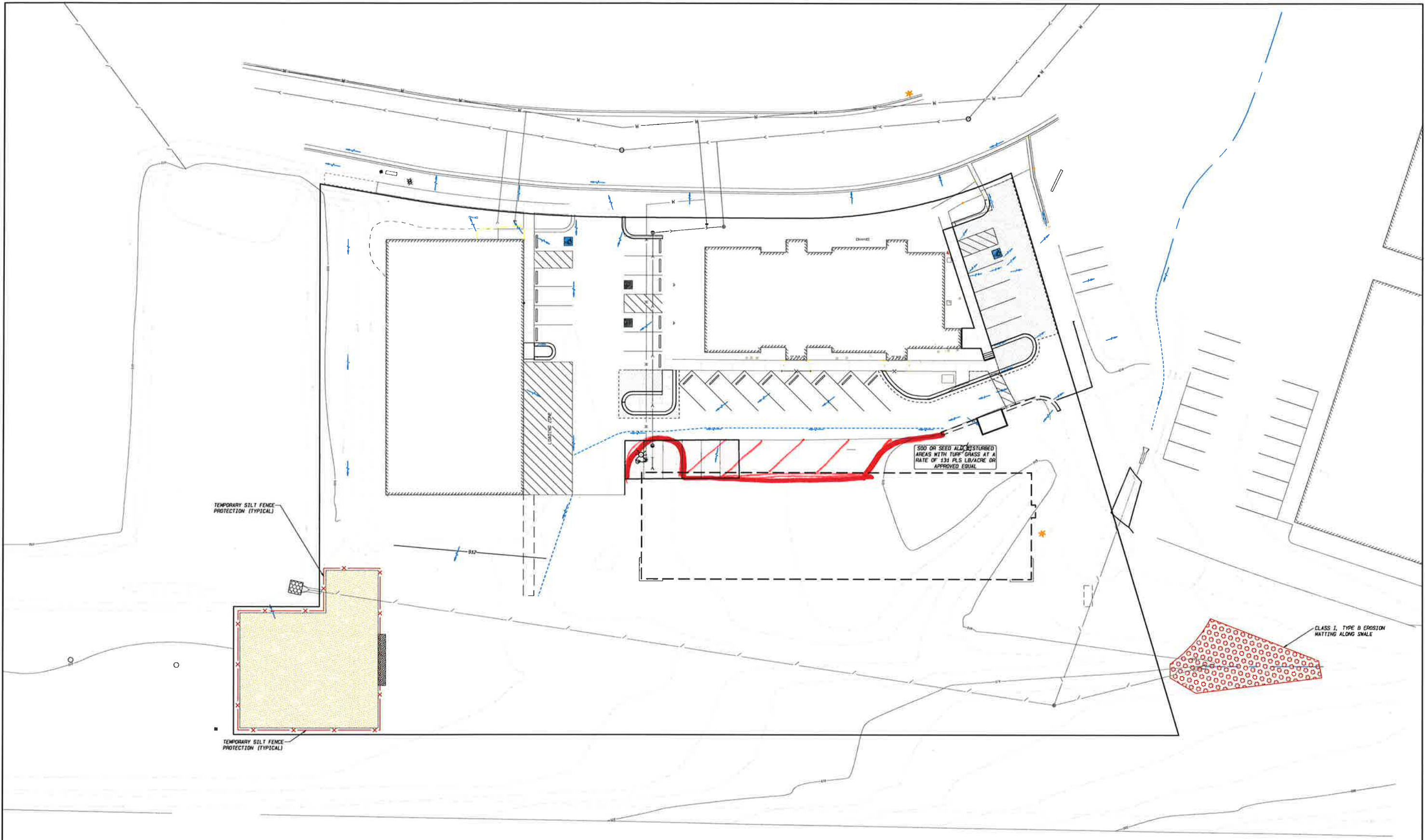

TEMPORARY SILT FENCE PROTECTION (TYPICAL)

TEMPORARY SILT FENCE PROTECTION (TYPICAL)

SOO OR SEED ALONG DISTURBED AREAS WITH TURF GRASS AT A RATE OF 131 PLS LB/ACRE OR APPROVED EQUAL

CLASS I, TYPE B EROSION MATTING ALONG SWALE

	• LAND SURVEYING	DATE	08/12/22	REVISIONS
	• LAND PLANNING	BY	AFG	10/24/22 City revisions AFG
	• CIVIL ENGINEERING	APPROVED		11/28/22 3rd Blog AFG
109 N. Milwaukee St. Janesville, WI 53440		tel: 608 752-0575 fax: 608 752-0534	PROJECT NO. 122-294	02/01/23 City revisions AFG



**GENERAL EROSION NOTES**

- THE STORM WATER POLLUTION PREVENTION PLAN (SWPPP) IS COMPRISED OF THIS DRAWING, THE EROSION CONTROL DETAILS, THE NOI PERMIT, SUBSEQUENT REPORTS AND RELATED DOCUMENTS.
- ALL CONTRACTORS AND SUBCONTRACTORS INVOLVED WITH STORM WATER POLLUTION PREVENTION SHALL OBTAIN A COPY OF THE SWPPP AND THE STATE OF WISCONSIN NATIONAL POLLUTANT DISCHARGE ELIMINATION SYSTEM GENERAL PERMIT (NPDES PERMIT) AND BECOME FAMILIAR WITH THEIR CONTENTS.
- CONTRACTOR SHALL IMPLEMENT BEST MANAGEMENT PRACTICES (BMP'S) AS REQUIRED BY THE SWPPP. ADDITIONAL BMP'S SHALL BE IMPLEMENTED AS DICTATED BY CONDITIONS AT NO ADDITIONAL COST OF THE OWNER THROUGHOUT ALL PHASES OF CONSTRUCTION.
- BEST MANAGEMENT PRACTICES AND CONTROLS SHALL CONFORM TO FEDERAL, STATE, OR LOCAL REQUIREMENTS, OR MANUAL OF PRACTICE, AS APPLICABLE. CONTRACTOR SHALL IMPLEMENT ADDITIONAL CONTROLS AS DIRECTED BY PERMITTING AGENCY OR OWNER.
- THE SITE MAP MUST CLEARLY DELINEATE ALL STATE WATER AND PERMITS FOR ANY CONSTRUCTION ACTIVITY IMPACTING STATE WATERS OR REGULATED WETLANDS, AND MUST BE MAINTAINED ON-SITE AT ALL TIMES.
- CONTRACTOR SHALL MINIMIZE CLEARING TO THE MAXIMUM EXTENT PRACTICABLE OR AS REQUIRED BY THE GENERAL PERMIT.
- GENERAL CONTRACTOR SHALL DENOTE ON PLAN THE TEMPORARY PARKING AND STORAGE AREA WHICH SHALL ALSO BE USED AS THE EQUIPMENT MAINTENANCE AND CLEANING AREA, EMPLOYEE PARKING AREA, AND AREA FOR LOCATING PORTABLE FACILITIES, OFFICE TRAILERS, AND TOILET FACILITIES.
- ALL WASH WATER (CONCRETE TRUCKS, VEHICLE CLEANING, EQUIPMENT CLEANING, ETC.) SHALL BE OBTAINED AND PROPERLY TREATED OR DISPOSED.
- SUFFICIENT OIL AND GREASE ABSORBING MATERIALS AND FLOATATION BOOMS SHALL BE MAINTAINED ON-SITE OR READILY AVAILABLE TO CONTAIN AND CLEAN UP FUEL OR CHEMICAL SPILLS AND LEAKS.
- DUST ON THE SITE SHALL BE CONTROLLED. THE USE OF MOTOR OILS AND OTHER PETROLEUM BASED OR TOXIC LIQUIDS FOR DUST SUPPRESSION OPERATIONS IS PROHIBITED.
- RUBBISH, TRASH, GARBAGE, LITTER, OR OTHER SUCH MATERIALS SHALL BE DEPOSITED INTO SEALED CONTAINERS. MATERIALS SHALL BE PREVENTED FROM LEAVING THE PREMISES THROUGH THE ACTION OF WIND OR STORM WATER DISCHARGE INTO DRAINAGE DITCHES OR WATERS OF THE STATE.
- ALL STORM WATER POLLUTION PREVENTION MEASURES PRESENTED ON THIS PLAN, AND IN THE SWPPP SHALL BE INITIATED AS SOON AS PRACTICABLE.
- DISTURBED PORTIONS OF THE SITE WHERE CONSTRUCTION ACTIVITY HAS STOPPED FOR AT LEAST 14 DAYS SHALL BE TEMPORARILY SEED. THESE AREAS SHALL BE SEEDING NO LATER THAN 14 DAYS FROM THE LAST CONSTRUCTION ACTIVITY OCCURRING IN THESE AREAS.
- DISTURBED PORTIONS OF THE SITE WHERE CONSTRUCTION ACTIVITY HAS PERMANENTLY STOPPED SHALL BE PERMANENTLY SEED. THESE AREAS SHALL BE SEEDING NO LATER THAN 14 DAYS AFTER THE LAST CONSTRUCTION ACTIVITY OCCURRING IN THESE AREAS. REFER TO THE GRADING PLAN AND/OR LANDSCAPING PLAN.
- IF THE ACTION OF VEHICLES TRAVELING OVER THE GRAVEL CONSTRUCTION ENTRANCES IS NOT SUFFICIENT TO REMOVE THE MAJORITY OF DIRT OR MUD, THEN THE TIRMS MUST BE WASHED BEFORE THE VEHICLES ENTER A PUBLIC ROAD. IF WASHING IS USED, PROVISIONS MUST BE MADE TO INTERCEPT THE WASH WATER AND ROAD THE SEDIMENT BEFORE IT IS CARRIED OFF THE SITE.
- ALL MATERIALS SPILLED, DROPPED, WASHED, OR TRACKED FROM VEHICLES ONTO ROADWAYS OR INTO STORM DRAINS MUST BE REMOVED IMMEDIATELY.
- CONTRACTORS OR SUBCONTRACTORS SHALL BE RESPONSIBLE FOR REMOVING SEDIMENT IN THE DETENTION PONDS AND ANY SEDIMENT THAT MAY HAVE COLLECTED IN THE STORM SEWER DRAINAGE SYSTEMS IN CONJUNCTION WITH THE STABILIZATION OF THE SITE.
- ON-SITE & OFF-SITE SOIL STOCKPILE AND BORROW AREAS SHALL BE PROTECTED FROM EROSION AND SEDIMENTATION THROUGH IMPLEMENTATION OF BEST MANAGEMENT PRACTICES. STOCKPILE AND BORROW AREA LOCATIONS SHALL BE NOTED ON THE SITE MAP AND PERMITTED IN ACCORDANCE WITH GENERAL PERMIT REQUIREMENTS.
- SLOPES SHALL BE LEFT IN A ROUGHENED CONDITION DURING THE GRADING PHASE TO REDUCE RUNOFF VELOCITIES AND EROSION.
- DUE TO THE GRADE CHANGES DURING THE DEVELOPMENT OF THE PROJECT, THE CONTRACTOR SHALL BE RESPONSIBLE FOR ADJUSTING THE EROSION CONTROL MEASURES (SILT FENCES, STRAW BALES, ETC.) TO PREVENT EROSION.
- ALL CONSTRUCTION SHALL BE STABILIZED AT THE END OF EACH WORKING DAY. THIS INCLUDES BACKFILLING OF TRENCHES FOR UTILITY CONSTRUCTION AND PLACEMENT OF GRAVEL OR BITUMINOUS PAVING FOR ROAD CONSTRUCTION.

**EROSION CONTROL PLAN NOTES:**

- PHASED CONSTRUCTION / STABILIZATION**  
TO ENSURE THAT DISTURBED AREAS ARE NOT VULNERABLE TO EROSION FOR EXTENDED PERIODS, THE SITE NEEDS TO BE BROKEN INTO ZONES OF LAND DISTURBANCE.  
WITHIN EACH ZONE, STABILIZE (E.G., SEED & MULCH, COMPOST, EROSION MAT, POLYMER) ALL DISTURBED AREAS OUTSIDE OF STREET RIGHT-OF-WAY BEFORE BREAKING GROUND IN THE NEXT ZONE. STABILIZATION SHALL OCCUR WITHIN 30 DAYS OF INITIAL GROUNDBREAKING OR WITHIN 7 DAYS OF ACHIEVING FINAL GRADE, WHICHEVER OCCURS FIRST.  
MULCH AS PART OF A STABILIZATION MEASURE SHALL BE APPLIED TO PRODUCE A CONTINUOUS COVER OF MULCH AND SHALL BE ANCHORED AT A RATE OF 2 TONS PER ACRE. IN ALL CASES, THE MULCH MUST BE ANCHORED INTO THE SOIL BY DISCING.
- CONSTRUCTION ENTRANCES/EXITS**  
CONTRACTOR SHALL PROVIDE A STONE TRACKING PAD AT THE POINT(S) OF ACCESS AS SHOWN ON THE PLANS. INSTALL ACCORDING TO MNR STANDARD 1057. REFER TO MNR'S WEB PAGE OF TECHNICAL STANDARDS AT: <http://dnr.wi.gov/org/water/wa/nps/stormwater/techstds.htm#Construction>
- WATER PROVISION**  
FOR THE FIRST SIX WEEKS AFTER INITIAL STABILIZATION (E.G., SEED & MULCH, EROSION MAT, SOD) OF A DISTURBED AREA, PROVISION SHALL BE MADE FOR WATERING WHENEVER MORE THAN 7 DAYS OF DRY WEATHER ELAPSE.
- TEMPORARY STABILIZATION USING ANTONIC POLYMER**  
ANTONIC POLYACRYLAMIDE WILL BE APPLIED TO ALL DISTURBED AREAS WHERE THE VILLAGE ENGINEER OR MNR REPRESENTATIVE'S DEEM STABILIZATION AND/OR EROSION TO BE PROBLEMATIC. APPLICATION OF POLYACRYLAMIDE WILL BE ACCORDING TO MNR CONSERVATION PRACTICE STANDARD 1058. EROSION CONTROL LAND APPLICATION OF ANTONIC POLYACRYLAMIDE. REFER TO MNR'S STORMWATER WEB PAGE OF TECHNICAL STANDARDS AT: <http://dnr.wi.gov/org/water/wa/nps/stormwater/techstds.htm>
- DEEP TILLING**  
FOLLOWING ROUGH GRADING, DEEP TILLING (A.K.A. SUBSOILING) WILL BE PERFORMED ON ALL GRADED AREAS OUTSIDE THE FOOTPRINT OF STREET FOOTPRINTS. THE OPERATION SHALL BE ACCOMPLISHED USING TWIN STRAIGHT STEEL SHANKS DRAWN BY TRACKED MACHINERY. EACH SHANK SHALL BE 24 TO 36 INCHES LONG, POSITIONED OVER THE TRACTOR TRACKS, AND SPACED 4 TO 5 FEET APART. DEEP TILLING SHALL BE DONE ON DRY SOIL AND ACROSS THE SLOPE. REFER TO THE DANE COUNTY EROSION CONTROL AND STORMWATER MANAGEMENT MANUAL, APPENDIX J.D.1, WHICH IS ACCESSIBLE FROM THE DANE COUNTY LAKES AND WATERSHED COMMISSION WEB SITE AT: <http://www.countydane.com/12wp/12kts/stormwatermanual.shtml>
- SOIL STOCKPILES**  
A ROW OF SILT FENCE PLACED DOWNSLOPE AND AT LEAST 10 FEET AWAY FROM SOIL STOCKPILES SHALL PROTECT ALL STOCKPILES. SOIL STOCKPILES THAT ARE INACTIVE FOR MORE THAN 14 CONSECUTIVE DAYS SHALL BE STABILIZED WITH SEED & MULCH, EROSION MAT, POLYMER, OR COVERED WITH TAMPERS OR SIMILAR MATERIAL.
- DEWATERING**  
WATER PUMPED FROM THE SITE SHALL BE TREATED BY USING A TEMPORARY SEDIMENTATION BASIN, PORTABLE DEWATERING BASIN OR AN EQUIVALENT DEVICE.  
ANY INDIVIDUAL SEDIMENTATION BASIN SHALL HAVE A DEPTH OF AT LEAST 3 FEET AND PROVIDE A MAXIMUM SURFACE SETTLING RATE OF 1500 GALLONS PER SQUARE FOOT PER DAY.  
THIS WATER SHALL BE DISCHARGED IN A MANNER THAT DOES NOT INDUCE EROSION OF THE SITE OR ADJACENT PROPERTY.
- STORM SEWER INLETS**  
PROVIDE MIXED TYPE D "CATCHALL" INLET PROTECTION OR EQUIVALENT. REFER TO MNR PRODUCT ACCEPTABILITY LIST AT: <http://www.dot.wisconsin.gov/business/engserv/pal.htm>. INLET PROTECTION SHALL BE INSTALLED PRIOR TO THE STORM SEWER SYSTEM RECEIVING SITE RUNOFF. OTHER THAN FOR PERIODIC MAINTENANCE, THESE DEVICES SHALL NOT BE REMOVED UNTIL FLAT-LEVEL STABILIZATION IS COMPLETE.
- INSPECTIONS**  
ALL EROSION CONTROL MEASURES AND STRUCTURES SERVING THE SITE MUST BE INSPECTED AT LEAST WEEKLY AND WHENEVER 0.5 INCHES OF RAIN OR MORE IS PRODUCED WITHIN 24 HOURS. ALL NECESSARY MAINTENANCE SHOULD FOLLOW THE INSPECTIONS WITHIN 24 HOURS.
- POND**  
THE STORM WATER POND SHALL BE CONSTRUCTED TO ALLOW SEDIMENTATION WITHIN THE POND DURING CONSTRUCTION, AND THE CLEANING OF THE POND FROM ACCUMULATED SEDIMENT AT THE COMPLETION OF CONSTRUCTION.

**MAINTENANCE**

- ALL MEASURES STATED ON THIS EROSION AND SEDIMENT CONTROL PLAN, AND IN SWPPP SHALL BE MAINTAINED IN FULLY FUNCTIONAL CONDITION UNTIL NO LONGER REQUIRED FOR A COMPLETED PHASE OF WORK OR FINAL STABILIZATION OF THE SITE. ALL EROSION AND SEDIMENTATION CONTROL MEASURES SHALL BE CHECKED BY A QUALIFIED PERSON IN ACCORDANCE WITH THE CONTRACT DOCUMENTS OR THE APPLICABLE PERMIT, WHICHEVER IS MORE STRINGENT, AND REPAIRED IN ACCORDANCE WITH THE FOLLOWING:
- INLET PROTECTION DEVICES AND BARRIERS SHALL BE REPAIRED OR REPLACED IF THEY SHOW SIGNS OF UNDERMINING, OR DETERIORATION.
  - ALL SEEDED AREAS SHALL BE CHECKED REGULARLY TO SEE THAT A GOOD STAND IS MAINTAINED. AREAS SHOULD BE FERTILIZED, WATERED, AND RESEED AS NEEDED.
  - SILT FENCES SHALL BE REPAIRED TO THEIR ORIGINAL CONDITIONS IF DAMAGED. SEDIMENT SHALL BE REMOVED FROM THE SILT FENCES WHEN IT REACHES ONE-HALF THE HEIGHT OF THE SILT FENCE.
  - THE CONSTRUCTION ENTRANCES SHALL BE MAINTAINED IN A CONDITION WHICH SHALL PREVENT TRACKING OR FLOW OF MUD ONTO PUBLIC RIGHTS-OF-WAY. THIS MAY REQUIRE PERIODIC TOP DRESSING OF THE CONSTRUCTION ENTRANCES AS CONDITIONS DEMAND.
  - THE TEMPORARY PARKING AND STORAGE AREA SHALL BE KEPT IN GOOD CONDITION (SUITABLE FOR PARKING AND STORAGE). THIS MAY REQUIRE PERIODIC TOP DRESSING OF THE TEMPORARY PARKING AS CONDITIONS DEMAND.
  - OUTLET STRUCTURES IN THE SEDIMENTATION BASINS SHALL BE MAINTAINED IN OPERATIONAL CONDITIONS AT ALL TIMES. SEDIMENT SHALL BE REMOVED FROM SEDIMENT BASINS OR TRAPS WHEN THE DESIGN CAPACITY HAS BEEN REDUCED.

**CONSTRUCTION SEQUENCE:**

- PHASE 1**
- Install stone tracking pad.
  - Prepare temporary parking and equipment storage area.
  - Install silt fencing where indicated.
  - Construct/excavate the temporary sedimentation basin (bio-filter area) and other diversions.
- HALT ALL ACTIVITIES AND CONTACT THE CIVIL ENGINEERING CONSULTANT TO PERFORM AN INSPECTION OF BEST MANAGEMENT PRACTICES (BMP'S). GENERAL CONTRACTOR SHALL SCHEDULE AND CONDUCT A STORM WATER PRE-CONSTRUCTION MEETING WITH ENGINEER AND ALL GRADE DISTURBING CONTRACTORS BEFORE PROCEEDING WITH CONSTRUCTION.**
- PHASE 2**
- Temporarily seed denuded areas.
  - Install utilities, underpains, stone sewers, curbs and gutters.
  - Install silt fencing where indicated.
  - Install inlet protection around all storm sewer structures.
  - Stabilize all areas that are to be seeded and able to be brought to finished grade with seeding or sod.
  - Stabilize all areas that are to be paved and that are able to be brought to subgrade elevation with compacted base material.
  - Grade all possible areas while maintaining diversions and basins.
  - Stabilize all areas that are to be seeded and able to be brought to finished grade with seeding or sod.
  - Stabilize all areas that are to be paved and that are able to be brought to subgrade elevation with compacted base material.
  - Maintain 70% stabilization within disturbed areas.
- PHASE 3**
- Backfill and stabilize diversions and basin.
  - Pave site.
  - Complete grading.
  - Remove all temporary erosion and sediment control devices (only if site is stabilized). Remove sediment from temporary sedimentation basin. Install engineered mix within bio-filter. Remove bio-filter silt fencing.

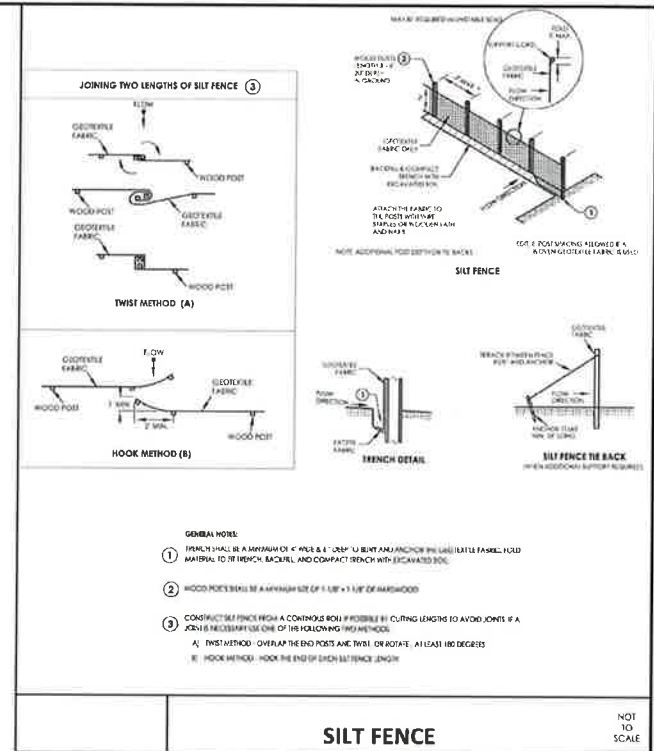
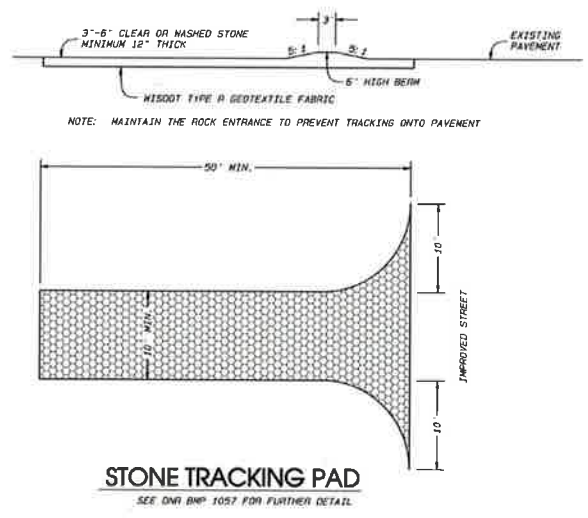
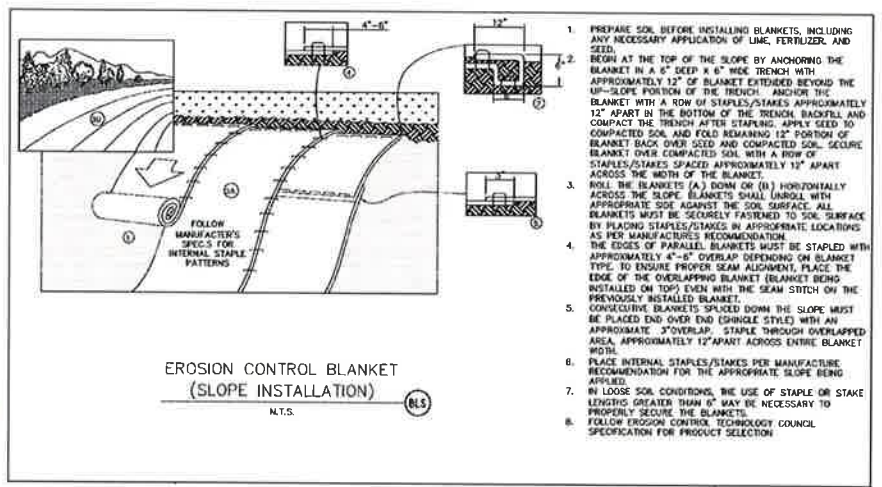
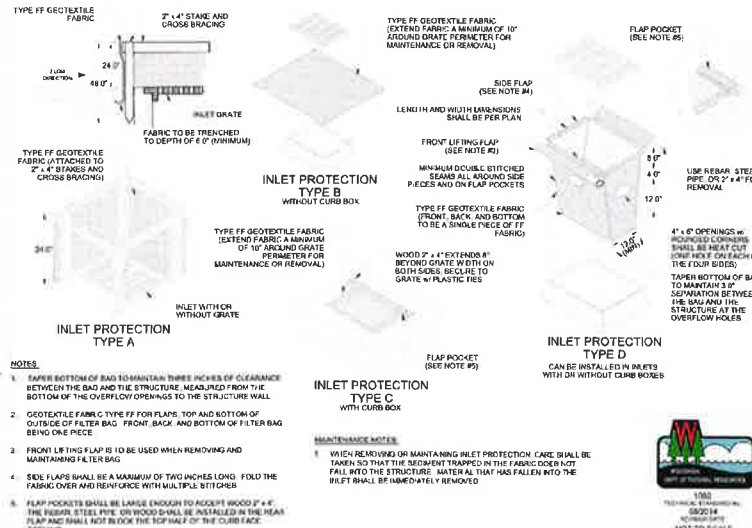

FIGURE 1. INLET PROTECTION TYPES A, B, C AND D



<b>Combs &amp; Associates</b>	DATE	08/12/22	REVISIONS	10/24/20 City revisions #6
	BY	AFG		11/28/20 3rd Bldg #8
	APPROVED			02/16/23 City revisions #8
	PROJECT NO.	122-294		
109 N. Milwaukee St. Janesville, WI 53401		TEL: 608 752-0575		
		FAX: 608 752-0534		





**AMENDMENT #1 TO DEVELOPMENT AGREEMENT  
FOR DEVELOPMENT OF LOT 2 – Mixed Use Property**

WHEREAS, the City of Evansville, a municipal corporation, (“CITY”) and Phillips-Morning Investment Group, LLC (DEVELOPER) entered into a Development Agreement for the development of Lot 2 – Mixed Use Property that was approved and executed October 8, 2018, but not recorded; and

WHEREAS, the DEVELOPER, has pursued development on the property, constructing two of the anticipated three buildings on parcel 6-27-958.091A1 within TID #9; and

WHEREAS, the DEVELOPER and the CITY have mutually claimed the other has not complied with certain terms of the original Development Agreement (“Exhibit A”); and

WHEREAS, the DEVELOPER and the CITY, desire to amend to the original Development Agreement to alter the incentive payments to the developer and terminate the original Development Agreement; and

WHEREAS, the original Development Agreement dated October 9, 2018 allows revisions to be made in writing with both parties executing and signing any revisions:

NOW, THEREFORE, in consideration of these recitals and the mutual covenants set forth below, the DEVELOPER and the CITY mutually agree this \_\_ day of April, 2023, that the original Development Agreement be amended as follows:

1. The CITY of Evansville approved a site plan application on April 4, 2023 for the parcel identified in the original Development Agreement (Parcel # 6-27-958.091A1) with conditions that include acceptance of this amendment.
2. The CITY and the DEVELOPER agree to comply with all City of Evansville ordinances and other requirements as the DEVELOPER develops the property pursuant to the referenced site plan approval.
3. The CITY and the DEVELOPER will sign and execute this amendment no later than April 13, 2023.
4. The CITY will provide a one-time incentive payment to the DEVELOPER of \$150,000 no later than April 14, 2023. This payment reflects the missed incentive payments due or from 2021, 2022, and 2023 as well as reimbursements owed for stormwater work, pursuant to the original Development Agreement.
5. Both parties acknowledge that all obligations to each other, under the original Development Agreement dated October 9, 2018, are deemed satisfied.
6. Both parties release the other party from any and all claims that they might have and/or assert pursuant to the terms of the original Development Agreement.
7. If any term of this Amendment shall, for any reason and to any extent, be invalid or unenforceable, the remaining terms shall be given force and effect.

Agenda Item **7B**

- 8. This Amendment constitutes the entire agreement of the CITY and the DEVELOPER. It shall only be modified by the written agreement of both parties.
- 9. This Amendment shall be permanent and run with the land, and the rights, grants, and responsibilities assumed thereby shall inure to, and be binding upon, the parties, their heirs, successors and assigns.

IN WITNESS WHEREOF, the parties have caused this Amendment to be executed on the date first above stated.

**City of Evansville**

\_\_\_\_\_  
Dianne Duggan, Mayor

\_\_\_\_\_  
Leah Hurlley, City Clerk

**Morning Investment Group, LLC.**

\_\_\_\_\_  
\_\_\_\_\_  
(print name and title)

\_\_\_\_\_  
\_\_\_\_\_  
(print name and title)



Exhibit A  
2018 Development Agreement

**UNBINDING DEVELOPMENT AGREEMENT  
DEVELOPMENT OF LOT 2 – Mixed Use Property**

THIS AGREEMENT is approved this 9th day of October, 2018, by and between the City of Evansville and Phillips-Morning Investments LLC:

**RECITALS**

Phillips-Morning Investments LLC, (“DEVELOPER”), is a Wisconsin limited liability company;

The City of Evansville (“CITY”) is a municipal corporation of Rock County, Wisconsin;

The DEVELOPER wishes to build mixed use residential-commercial buildings located on Lot 2 on Brown School Road identified as parcel number 6-27-958.091A1 (“PROPERTY”);

The PROPERTY is zoned B-3, and the Plan Commission has approved a concept site plan. Final site plan and conditional use permit approval for the development of mixed use buildings on the PROPERTY is required;

The taxable value of Building #1 (approximate 9,362 square feet of commercial/retail space) is estimated to be \$780,000;

The taxable value of Building #2 (approximate 6,000 square feet of commercial or residential space on the lower level and approximate 4,000 square feet or more residential space on the second level with a minimum of 3 residential units) is estimated to be \$979,000;

The taxable value of Building #3 (approximate 7,800 square feet of commercial/warehouse/light industrial space) is estimated to be \$340,600;

The taxable value of parking lot and site improvements is estimated to be \$40,000;

The taxable value of land improvements is estimated to be \$205,000;

The City has built in a contingency of 15% in the aggregate dollar amounts of allowable tax reimbursement due to any future mill rate or valuation increases.

There are improvements necessary within public infrastructure to maximize density. These improvements include stormwater diversion and detention for the proposed development, neighboring properties, and public right-of-way.

Minimum standards for on-site stormwater filtration serves the property solely and is not a public good or utility. Filtration construction and maintenance of on-site filtration must remain under the control and design of the developer and future property owners. Any

improvements to increase filtration or on-site detention greater than the proposed plan may be eligible for a stormwater credit per the City's stormwater credit manual.

Additional improvements to be reimbursed by the City to the developer include water and sewer connection capable of meeting potential growth in Building #3.

The Municipal Services Committee has met and agreed to waive the sewer connection fees as part of economic growth and encouraged density. Fee waiver shall apply to the first two buildings constructed.

Tax Incremental District No. 9 ("TID #9") is anticipated to be created by the CITY before September 30, 2018 as a Mixed Use District Overlay to assure a combination of industrial, commercial and residential;

NOW, THEREFORE, in consideration of these recitals and the mutual covenants set forth below, the DEVELOPER and CITY mutually agree as follows:

### **DEVELOPMENT OF MIXED USE PROPERTY**

DEVELOPER shall undertake the following:

1. Purchase the PROPERTY.
2. Obtain final site plan and permit approval for the development of mixed use buildings on the PROPERTY.
3. Construct the first building before December 31, 2019.
4. Construct the second building to ensure mixed use within the district, before December 31, 2023
5. Construct all improvements as required by authoritative bodies such as but not limited to the CITY, Plan Commission, and State of Wisconsin.
6. All plans shall be reviewed and approved by the CITY and all costs for the review shall be reimbursed by the DEVELOPER when the CITY submits an invoice. All invoices for reimbursement shall be sent to the DEVELOPER within 90 days of the CITY receiving the original invoice.
7. Provide equitable opportunity for local contractors to compete for subcontracts in development.

### **TAX INCREMENT FUNDS**

CITY shall provide to the DEVELOPER an annual reimbursement in the amount of 100% of the tax generated by the increment value of the PROPERTY, not to exceed \$240,000 in aggregate or until the 2033 taxable year annually, for the completion of Buildings #1.

CITY shall provide to the DEVELOPER an annual reimbursement in the amount of 100% of the tax generated by the increment value of the PROPERTY, not to exceed \$220,000 in aggregate or until the 2033 taxable year annually. Completion requires minimum of 3 residential units.

CITY shall provide to the DEVELOPER an annual reimbursement in the amount of 100% of the tax generated by the increment value of the PROPERTY, not to exceed \$320,000 in aggregate or until the 2033 taxable year annually, for the completion of Buildings #3.

CITY shall provide to the DEVELOPER site work and utility connections for stormwater, consisting of above ground or underground stormwater diversion, expansion of the detention basin if needed, initial grading work to remove drainage of Highway 14 off Developer's property and into the Right-of-Way or agreed drainage easements. This is an estimated cost of up to \$30,000 to be reimbursed by TID #9 to the Stormwater Fund when funds are available. This excludes any and all ownership or responsibility of filtration infrastructure by the City.

CITY shall provide to the DEVELOPER utility connections for water and sanitary sewer to Building #3. The City will reimburse costs for the installation of sewer and water connections that will be made pursuant to the city's standards, requirements, and direction for such infrastructure and for future expansion of Building #3. This is an estimated cost of up to \$15,000 to be reimbursed by TID #9 to the Sewer and Water Funds when funds are available.

Eligible infrastructure costs to be possibly reimbursed to the DEVELOPER for utility construction are engineering costs, materials and labor. All submissions are to be reviewed by the City Engineer to confirm that the reimbursement request is reasonable and accurate. The City will only reimburse what is deemed reasonable and accurate.

CITY shall waive the Sewer Connection Fees in an amount not to exceed \$23,400 for the first and second constructed buildings.

The DEVELOPER shall pay, when due, all taxes, reimbursements and assessments levied against the PROPERTY.

The DEVELOPER shall pay construction costs and shall submit reimbursement requests within 90 days of paying the invoice. Proof of payment shall be submitted with the reimbursement request.

The DEVELOPER must complete two of the three buildings on or before December 31, 2023. If the DEVELOPER fails to construct two of the three buildings as described, the DEVELOPER shall upon order of the CITY, reimburse all incentives to the CITY and all future incentives suspended.

This agreement is contingent upon the successful creation and establishment of TID #9 as shown in ATTACHMENT B.

This AGREEMENT shall be recorded with the Rock County Register of Deeds at the expense of the DEVELOPER immediately after signing and the DEVELOPER shall provide proof of such to the CITY.

Any alterations to this AGREEMENT, including but not limited to division of incentives with future property owners, shall be made through amendments submitted to the CITY in writing, approved by the governing body of the CITY, attached to this original AGREEMENT and recorded with Rock County Register of Deeds at the expense of the DEVELOPER. Proof of recording shall be provided to the CITY.

### **PERSONAL GUARANTEE**

Each and every individual member of DEVELOPER shall be jointly and severally liable for each and every obligation imposed upon or undertaken by DEVELOPER under this AGREEMENT.

By signing this AGREEMENT, each principal officer of DEVELOPER hereby grants a personal guarantee to be responsible for the obligations and duties of the DEVELOPER under this AGREEMENT.

This AGREEMENT and PERSONAL GUARANTEE shall be applicable to and the responsibility of all future owners of the parcel or parcels if divided until the completion of this AGREEMENT.

### **EVENTS AND REMEDIES OF DEFAULT**

In the event of default of any term, promise, covenant, condition or representation in this AGREEMENT, upon thirty (30) days written notice of the right to cure such default, the non-defaulting party may pursue any legal or administrative action which appears necessary or desirable to compel the defaulting party to comply with this AGREEMENT and/or to seek an award of monetary damages.

### **MISCELLANEOUS**

**Out of Pocket Expenses.** In consideration of professional staff time necessary for CITY to prepare, assemble or analyze documents associated with the tax increment projections and preparation of this AGREEMENT, CITY may utilize tax incremental proceeds for expenses due to the use of professional staff, including, but not limited to, financial adviser, assessor, city engineer, and city attorney.

**Captions.** Any captions of the several parts of this AGREEMENT are inserted for convenience of reference only and shall be disregarded in construing or interpreting any of its provisions.

**Severability.** If any term of this AGREEMENT shall, for any reason and to any extent, be invalid or unenforceable, the remaining terms shall be in full force and effect.

Entire Agreement. This AGREEMENT contains all of the terms, promises, covenants, conditions and representations made or entered into by or between CITY and DEVELOPER and supersedes all prior discussions and agreements whether written or oral between the parties. This AGREEMENT constitutes the sole and entire AGREEMENT between CITY and DEVELOPER and may not be modified or amended unless set forth in writing and executed by CITY and DEVELOPER with the formalities hereof.

Status of City. Nothing herein shall be deemed to create or establish the CITY as a copartner or joint venturer with DEVELOPER in the design, construction, ownership or operation of the PROPERTY; nor shall the CITY be entitled to proceeds or revenues derived from the ownership or operation of the PROPERTY.

Good Faith. Any actions taken pursuant to this AGREEMENT will be measured by an implied covenant of good faith and fair dealing.

Indemnification of City. DEVELOPER shall defend and indemnify the CITY against any and all claims brought or actions filed against CITY or any of its officers, employees or agents for property damage, bodily injury, death or other actions arising out of or relating to the DEVELOPER'S work, obligations or actions under this AGREEMENT.

Assignment. DEVELOPER'S obligations under this AGREEMENT cannot be assigned without prior consent of CITY and such consent shall not be unreasonably withheld.

Notice. All notices, demands or consents provided for in this AGREEMENT shall be in writing and shall be delivered to the parties hereto by hand or by United States mail. All such communications shall be addressed at the following, or other such address as either may specify to the other in writing:

To DEVELOPER:  
Phillips-Morning Investments LLC  
7902 North Country Rd M,  
Evansville, WI 53536

To CITY:  
Evansville City Administrator  
31 S. Madison St.  
PO Box 76  
Evansville, WI 53536

Binding Effect. This AGREEMENT shall be permanent and run with the PROPERTY, as described above, and the rights granted and responsibilities assumed thereby shall inure to, and be binding upon, the parties, their heirs, successors and assigns.

Law and Venue. This AGREEMENT shall be interpreted by the laws of the State of Wisconsin and venue for any dispute will be with the Rock County, Wisconsin Circuit Court.

DRAFT

**SIGNATURES**

IN WITNESS WHEREOF, the parties have caused this AGREEMENT to be executed on the date first above stated.

**City of Evansville:**

\_\_\_\_\_  
William C. Hurtley, Mayor

\_\_\_\_\_  
Judy L. Walton, City Clerk

:

\_\_\_\_\_  
Andrew E. Phillips, Partner/owner

\_\_\_\_\_  
John W. Morning, Partner/owner

The obligations of the Developer stated above in this Development Agreement are hereby personally guaranteed by the undersigned, who state they fully understand and accept the responsibilities of the Developer.

\_\_\_\_\_  
Andrew E. Phillips, Partner/owner

\_\_\_\_\_  
John W. Morning, Partner/owner





## APPLICATION FOR LAND DIVISION AND REZONE – STAFF REPORT

**Application No.:** RZ-2022-0047, LD-2023-0048

**Applicant** Sue White (Sienna Crest Assisted Living)

**Parcels:** 6-27-559.5170, 6-27-559.5171

**March 31, 2023**

Prepared by: Colette Spranger, Community Development Director

Direct questions and comments to: [colette.spranger@ci.evansville.wi.gov](mailto:colette.spranger@ci.evansville.wi.gov) or 608-882-2263

**Location:** Lots 170 and 171, Westfield Meadows First Addition

**Description of request:** An application to rezone parcel 6-27-559.5171 and amend lot lines between parcels 6-27-559.5170 and 6-27-559.5171 has been submitted for consideration by the Plan Commission.

**Existing and Proposed Zoning:** This request is related to a similar rezone that was granted in November 2022 for Lot 170 of Westfield Meadows. A separate site plan and conditional use permit application will be reviewed at the May Plan Commission meeting for the first phase of assisted living facilities on Lot 170. What the land division application does here is adjusts the lot lines between the two parcels in order for the entire proposed facility on that site plan to fit on one parcel. The rezone application would ensure that Lot 170 would not have split zoning after the land division.

Lot 171 is currently zoned R-3, Residential District Three. Given the plans for each lot are interconnected, I would not be opposed to rezoning Lot 171 entirely to R-3 right now. The applicant proposes a second phase of assisted living facilities on Lot 171. The remainder of Lot 171 should be rezoned to B-3 in order for the two facilities to follow the same zoning standards. Assisted living facilities are conditional uses in the B-3 zoning district. Within this district, the City's zoning code includes specific standards for institutional residential site development. These standards are a way of ensuring that development in this location is complimentary to the adjacent residential neighborhood. Hypothetically, development of Lot 171 could yield 100 multifamily units within its current zoning district. This is worth noting because what the applicant is proposing is much a far less intense use than what could be permitted by the City in this location.

Another public hearing will be held next month for the conditional use and site plan on Lot 170.

**Consistency with the City of Evansville Comprehensive Plan and Municipal Code:** Lot 171 is planned for future mixed uses. Therefore, the proposed land uses are thoroughly consistent with the Future Land Use Map of the Comprehensive Plan.

### Staff Recommended Motions:

***Motion to recommend that Common Council approve Ordinance 2023-05, Rezoning Territory from Residential District Three (R-3) to Community Business District (B-3).***

Motion to recommend Common Council approve a certified survey map to adjust the lot lines between tax parcels 6-27-559.5170 and 6-27-559.5171 finding that the application is in the public interest and meets the objectives contained within Section 110-102(g) of city ordinances, with the following conditions:

- 1) The applicant submits a joint cross access and maintenance agreement to City staff for review prior to recording
- 2) The CSM and joint cross access and maintenance agreement is recorded with the Rock County Register of Deeds.



**Current Zoning**



Lot line adjustment proposed with this application



Potential CBRF/RCAC site at build out



R-3



B-1



B-3

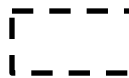

Area proposed to be rezoned to B-3

CITY OF EVANSVILLE  
ORDINANCE # 2023-5

**An Ordinance Rezoning Territory from Local Business District (B-1)  
to Community Business District (B-3)**  
(On Parcel 6-27-559.5170)

The Common Council of the City of Evansville, Rock County, Wisconsin, do ordain as follows:

**SECTION 1. Zoning Classification.** In accordance with Section 130-171 to 130-176, Evansville Municipal Code, Section 62.23(7)(d)2 of the Wisconsin State Statutes and upon recommendation of the Plan Commission and the findings of the Common Council that such zoning district change is in the best interest of the City, and all necessary notices having been given, and the required public hearing having been held, and the Plan Commission having made its recommendation of approval in writing to the Common Council, that the zoning classification of parcels be changed from Residential District Three (R-3) to Community Business District (B-3). The areas to be rezoned are indicated on the map below:

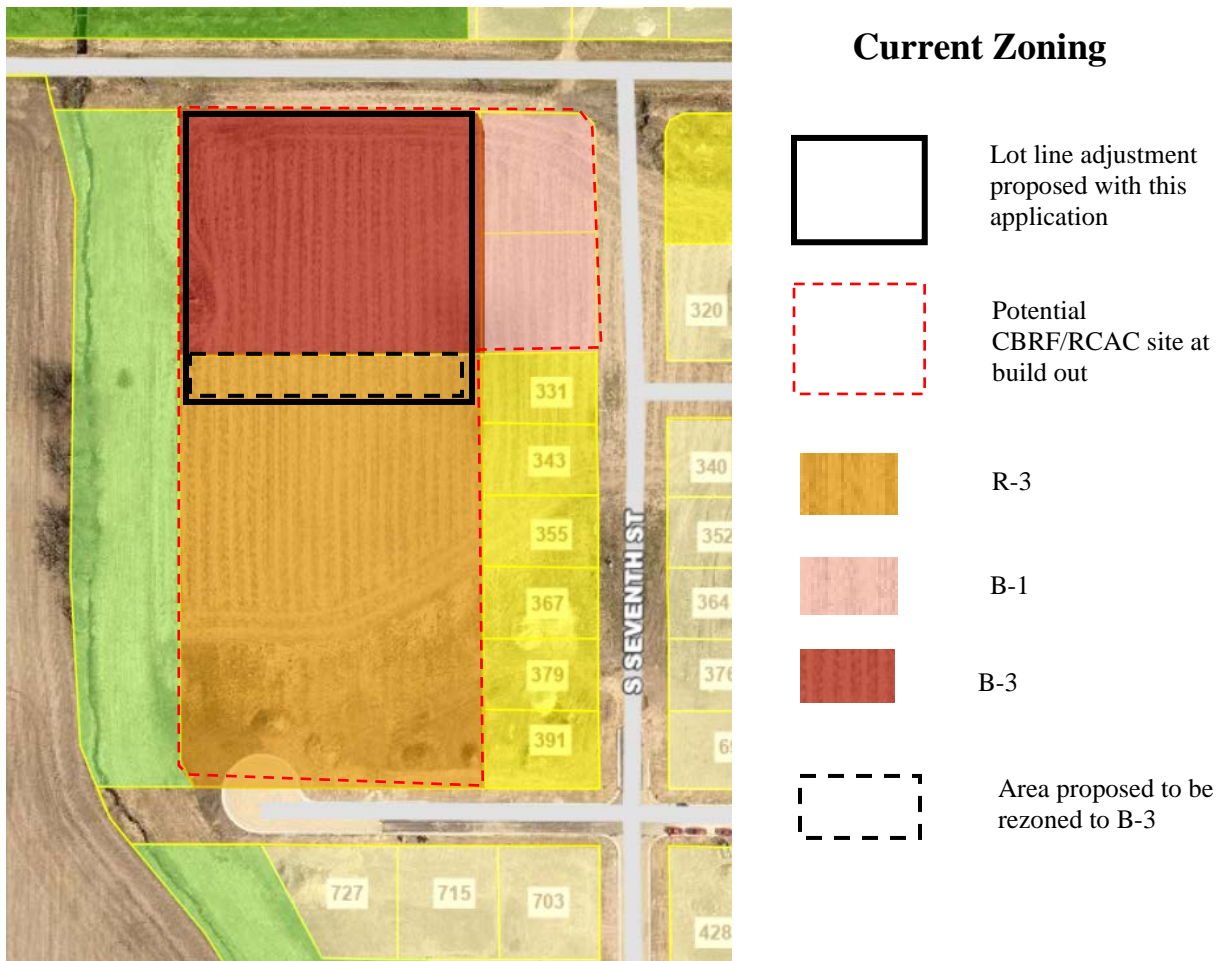

**SECTION 2. Zoning Map Amendment.** The official zoning map, City of Evansville, Wisconsin, is hereby amended to show the territory described in Section 1 as Community Business District Three (B-3).

**SECTION 3. Severability.** If any provision of this Ordinance is invalid or unconstitutional, or if the application of the Ordinance to any person or circumstances is invalid or unconstitutional, such invalidity or unconstitutionality shall not affect the other provisions or applications of this Ordinance which can be given effect without the invalid or unconstitutional provision or application.

**SECTION 4. Effective Date.** This Ordinance shall take effect upon its passage and publication as provided by law.

Passed and adopted this \_\_\_ day of May, 2023.

\_\_\_\_\_  
Dianne C. Duggan, Mayor

ATTEST:

\_\_\_\_\_  
Leah Hurtley, City Clerk

Introduced: 04/04/2023  
Notices published: 3/15/23, 3/22/23  
Public hearing held: 04/04/2023  
Adopted: 05/00/2023  
Published: (within 10 days of adoption)

*Sponsor: This ordinance was initiated by a landowner application for a zoning map amendment.*

*Drafted on 4/3/2023 by Colette Spranger, Community Development Director*

# PRELIMINARY CERTIFIED SURVEY MAP

LOTS 170 AND 171 OF WESTFIELD MEADOWS FIRST ADDITION, A RECORDED SUBDIVISION IN THE CITY OF EVANSVILLE, ROCK COUNTY, WISCONSIN

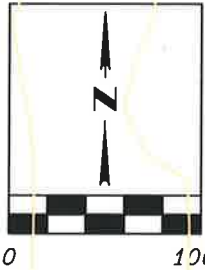

PORTER ROAD

S89°43'24"E

347.33'

10' UTILITY EASEMENT  
DOC. NO. 1766444

170

CURRENT ZONING: B-3  
CURRENT OWNER:  
JUST 1 MORE INVESTMENTS, LLC  
845 MARKET ST.  
OREGON, WI 53575

**LOT 1**

111,722 SF  
(2.565 AC)

AT&T EASE  
DOC. NO.  
1790523

CURRENT ZONING: R-3  
PROPOSED ZONING: B-3

S89°42'28"W 347.32'

10' UTILITY EASEMENT  
DOC. NO. 1766444

171

CURRENT ZONING: R-3  
CURRENT OWNER:  
JUST 1 MORE INVESTMENTS, LLC  
845 MARKET ST.  
OREGON, WI 53575

**LOT 2**

157,258 SF  
(3.610 AC)

N89°42'34"W

333.67'

BADGER DRIVE

WESTFIELD MEADOWS

WESTFIELD MEADOWS

WESTFIELD MEADOWS 1ST

WESTFIELD MEADOWS 1ST

S. SEVENTH STREET

FLOOD FRINGE  
PER FIRM

OUTLOT 5

N0°17'32"W

426.41'

N28°43'11"W  
28.70'

33' 33'

S0°17'32"E

33' 33'

774.99'

455.04'

319.95'

168

169

49  
333 S. 7TH ST.

48  
343 S. 7TH ST.

47  
355 S. 7TH ST.

46  
367 S. 7TH ST.

45  
379 S. 7TH ST.

44  
391 S. 7TH ST.

DEVELOPER:  
SIENNA CREST ASSISTED LIVING  
845 MARKET ST.  
OREGON, WI 53575



# REZONE MAP

LOTS 170 AND 171 OF WESTFIELD MEADOWS FIRST ADDITION, A RECORDED SUBDIVISION IN THE CITY OF EVANSVILLE, ROCK COUNTY, WISCONSIN

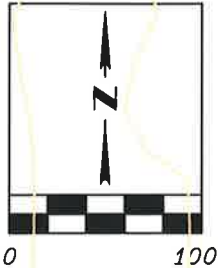

**PORTER ROAD**

40' 40'  
 S89°43'24"E 347.33'

10' UTILITY EASEMENT  
 DOC. NO. 1766444

170  
 CURRENT ZONING: B-3  
 CURRENT OWNER:  
 JUST 1 MORE INVESTMENTS, LLC  
 845 MARKET ST.  
 OREGON, WI 53575

**LOT 1**  
 111,722 SF  
 (2.565 AC)

AT&T EASE  
 DOC. NO. 1790523

Parcel 1 6-27-599.5170

323.40  
 749.81'  
 30'  
 30'  
 319.95'

CURRENT ZONING: R-3  
 PROPOSED ZONING: B-3

S89°42'28"W 347.32'

10' UTILITY EASEMENT  
 DOC. NO. 1766444

171  
 CURRENT ZONING: R-3  
 CURRENT OWNER:  
 JUST 1 MORE INVESTMENTS, LLC  
 845 MARKET ST.  
 OREGON, WI 53575

**LOT 2**  
 157,258 SF  
 (3.610 AC)

Parcel 1 6-27-599.5171

426.41'  
 N0°17'32"W  
 455.04'

N89°42'34"W 333.67'

**BADGER DRIVE**

168  
 169  
 49  
 333 S. 7TH ST.  
 48  
 343 S. 7TH ST.  
 47  
 355 S. 7TH ST.  
 46  
 367 S. 7TH ST.  
 45  
 379 S. 7TH ST.  
 44  
 391 S. 7TH ST.

WESTFIELD MEADOWS  
 WESTFIELD MEADOWS 1ST  
 WESTFIELD MEADOWS 1ST

774.99  
 749.81'  
 319.95'  
 455.04'

**S. SEVENTH STREET**

FLOOD FRINGE  
 PER FIRM

OUTLOT 5

N28°43'11"W  
 28.70'

DEVELOPER:  
 SIENNA CREST ASSISTED LIVING  
 845 MARKET ST.  
 OREGON, WI 53575



**APPLICATION FOR CONDITIONAL USE PERMIT – STAFF REPORT**

**Application:** CUP-2023-0054 **Applicant:** Main Street Fix (Tori Olson)

Parcel 6-27-25

March 31, 2023

Prepared by: Colette Spranger, Community Development Director

Direct questions and comments to: [colette.spranger@ci.evansville.wi.gov](mailto:colette.spranger@ci.evansville.wi.gov) or 608-882-2263

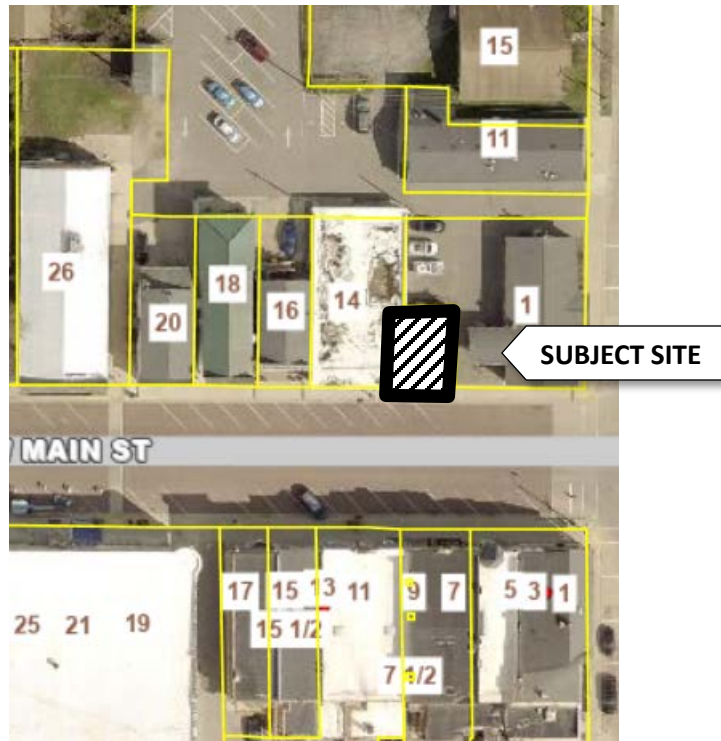

*Figure 1 Approximate Location Map*

**Location:** 8 W. Main Street

**Description of request:** The applicant is operating a smoothie/nutritional beverage shop as part of an Herbalife franchise. **The applicant is seeking conditional use permit approval to allow Indoor Commercial Entertainment on parcel 6-27-25 within the B-2 zoning district.**

**Existing/Prior Uses:** The previous use at this location was for a retail store.

**Staff Analysis of Request:**

The City is keen to encourage business in the downtown that generates foot traffic and encourages customers to visit multiple businesses within the same trip.

Sidewalk cafes are permitted temporary uses in the B-2 district. The applicant is welcome to offer outdoor seating in this location that adheres to the City's sidewalk café standards. The

sidewalk café standards are included at the end of this report. It is on the applicant to adhere to those standards.

**The business is already operating.** Standard procedures for operating an indoor commercial entertainment use in the City is to acquire the conditional use permit first, as there is always a possibility the City would have reason to deny the application. What happened here? In an incredibly strange turn of events, I spoke with two individuals at City Hall in January about opening up an Herbalife nutrition club in this exact location. I gave them my business card and the conditional use permit application, explaining that I would need the application approved prior to their opening. A few weeks later, I noticed that there was activity inside the building as if the business was proceeding. I waited for the application to be submitted. It never came and I then was told that a opening date had been set by the business owners. To my surprise when I went to inspect on site, there were two completely different people in charge who had no clue who I talked to in January. It seems two different sets of people were inquiring about the location for the same use at the same time. After checking with the Rock County Health Department to see if they had acquired the permits they needed (they had, and had passed the health inspection) I made the decision to allow the use to open as they planned.

In short: I assumed I had already approached them about their permit needs and was waiting for them to submit their applications. I did not realize my error until after the deadline had passed for the March Plan Commission meeting, which would have roughly aligned with their opening date. My intention here is not to set a precedent where businesses are encouraged to operate without approvals, but to acknowledge that in this case a bizarre turn of events led to me not reaching out earlier. I would have issued a stop work order if they hadn't had their health inspection.

**Required Plan Commission findings for Conditional Use Permit request:** Section 130-104(3) of the Municipal Code, includes criteria that should be considered in making this decision:

1. **Consistency of the use with the comprehensive plan.** The proposed use in general and in this specific location is consistent with the city's comprehensive plan of October 2023.  
*Staff Comment: Policies in the Comprehensive Plan provide support for variety and diversification of uses in its historic downtown.*
2. **Consistency with the City's zoning code, or any other plan, program, or ordinance.** The proposed use in general and in this specific location is consistent with City's zoning code, or any other plan, program, or ordinance, whether adopted or under consideration pursuant to official notice of the city.  
*Staff comment: The proposed use, indoor commercial entertainment, is consistent with the City's zoning code and other plans, programs, and ordinances.*
3. **Effect on nearby property.** The use will not result in a substantial or undue adverse impact on nearby property, the character of the neighborhood, environmental factors, traffic factors, parking, public improvements, public property or rights-of-way, or other matters affecting the public health, safety, or general welfare, either as they now exist or as they may in the future be developed as a result of the implementation of the City's zoning code, the comprehensive plan, or any other plan, program, map, or ordinance adopted or under consideration pursuant to official notice by the city.  
*Staff Comment: The applicant is asking for a waiver of parking requirements in the B-2 zoning district. This has been allowed with other businesses operating requesting similar conditional use permits in the downtown.*



4. **Appropriateness of use.** The use maintains the desired consistency of land uses, land use intensities, and land use impacts as related to the environs of the subject property.

*Staff Comment: This location is an appropriate use for an entertainment business.*

**Utilities and public services.** The use will be adequately served by, and will not impose an undue burden on, any of the improvements, facilities, utilities, or services provided by the City or any other public agency serving the subject property.

*Staff Comment: the property is currently served by public utilities*

**Required Plan Commission conclusion:** Section 130-104(3)(f) of the Municipal Code requires the Plan Commission to determine whether the potential public benefits of the conditional use do or do not outweigh any and all potential adverse impacts. The proposed motion below states that benefits do in fact outweigh any and all potential adverse impacts.

**Staff recommended motion for Plan Commission:** *Motion to approve a Site Plan and issuance of Conditional Use Permit for indoor commercial entertainment (golf simulator) per section 130-408 on parcel 6-27-108, located at 1 E. Main Street, finding that the benefits of the use outweigh any potential adverse impacts, and that the proposed use is consistent with the required standards and criteria for issuance of a CUP set forth in Section 130-104(3)(a) through (e) of the Zoning Ordinance, subject to the following conditions:*

- 1) *The business operator, now and in the future, shall comply with all provisions in the City's Zoning Code, as may be amended, related to indoor commercial entertainment uses (Section 130-408).*
- 2) *The parking requirements for this use in this location shall be waived.*
- 3) *The business operator, now and in the future, shall comply with all provisions in the City's Zoning Code, as may be amended, related to sidewalk cafes. (Section 130-568).*
- 4) *Hours of operation shall be no earlier than 7am and no later than 10pm.*
- 5) *The business operator shall obtain and maintain all City, state, and county permits and licenses as may be required.*
- 6) *Any substantial changes to the business model, such as significant differences in hours of operation or type of business, shall require a review of the existing conditional use permit and the issuance of a new conditional use permit.*
- 7) *A sign application and Certificate of Appropriateness approval, issued by the Historic Preservation Commission, is required for any planned signage related to the business.*
- 8) *Use cannot create a public nuisance as defined by local and state law.*
- 9) *The Conditional Use Permit is recorded with the Rock County Register of Deeds.*

**Sec. 130-568. Sidewalk cafés.**

Sidewalk cafés include an area on a sidewalk or similar area within the public right-of-way where food is served and which is associated with a restaurant. The provisions of this section are intended to accomplish the following purposes: enhance the pedestrian ambiance of the city by promoting additional activity on city sidewalks and visual interest, enhance the appropriate use of existing public spaces; and increase economic activity in the area. This use is a permitted use in the B-2 district. Temporary use regulations are as follows:

- (1) *Location.* A sidewalk café shall be located directly in front of the restaurant with which it is associated and it shall be operated solely in conjunction with such restaurant.
- (2) *Obstructions.* A sidewalk café may not interfere with any public service facilities located within the street right-of-way, including public telephones, mailboxes, public signs, public benches, public art, public fountains, and bus stops. In addition, a sidewalk café may not interfere with fire escapes, drop ladders, building access points, and other points of normal or emergency access.
- (3) *Pedestrian movement.* No portion of the sidewalk café may impede pedestrian movement. Generally, a 4-foot wide unobstructed walkway allows adequate pedestrian movement.
- (4) *Planters.* Planters may be used as a visual amenity and to frame off the space allocated for the sidewalk café. The size of plant materials shall be compatible in scale with the immediate area. Hanging planters are not permitted.
- (5) *Lighting.* Lighting shall be limited to tabletop lamps of low intensity. The city administrator may allow additional lighting to provide appropriate levels for safety.
- (6) *Furnishings.* All furnishings shall fit the character of a public streetscape. Umbrellas over each table may be permitted if it does not create an obstruction.
- (7) *Floor covering.* A floor covering may not be used in the sidewalk café.
- (8) *Tables.* Round tables may not exceed 36 inches in diameter and square tables may not exceed 36 inches in width.
- (9) *Food preparation.* All food shall be prepared within the restaurant.
- (10) *Alcoholic beverages.* No alcoholic beverages may be served or consumed in the sidewalk café unless the proper licenses have been issued under Sec. 6-2, Sec. 6-43, and or Sec. 106-163.
- (11) *Off-street parking requirements:* One space per every three patron seats, calculated on the sum of the indoor and outdoor patron seats. This requirement may be waived by the plan commission, following a request from the applicant.

[Ord. 2005-21, Ord. 2022-05]



**APPLICATION FOR CONDITIONAL USE PERMIT – STAFF REPORT**

**Application:** CUP-2023-0059 **Applicant:** Hop Garden (Rich Joseph)

Parcel 6-27-6

March 31, 2023

Prepared by: Colette Spranger, Community Development Director

Direct questions and comments to: [colette.spranger@ci.evansville.wi.gov](mailto:colette.spranger@ci.evansville.wi.gov) or 608-882-2263

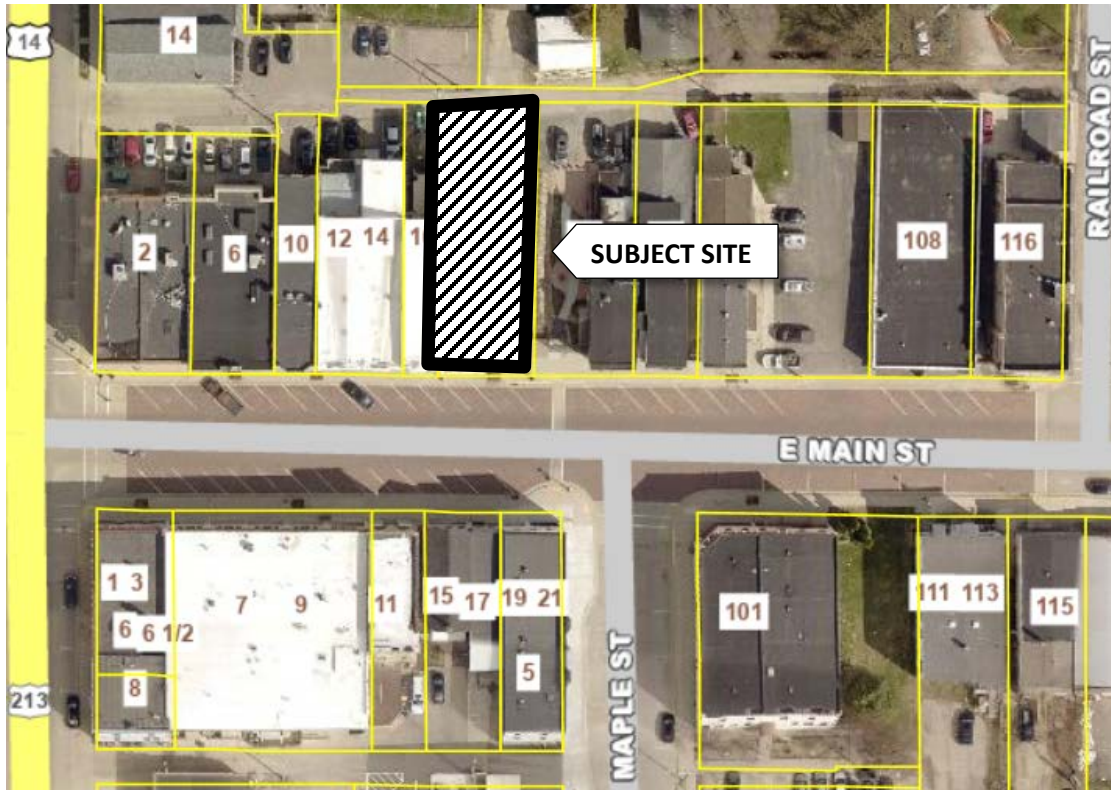

*Figure 1 Approximate Location Map*

**Location:** 18 E. Main Street

**Description of request:** The applicant is requesting to operate brewing equipment within a restaurant space. **The applicant is seeking conditional use permit approval to allow Light Industrial Use Incidental to Indoor Sales on parcel 6-27-6 within the B-2 zoning district.**

**Existing/Prior Uses:** The previous use at this location was for a restaurant. There is already a conditional use permit for indoor commercial entertainment recorded for this parcel.

**Staff Analysis of Request:**

The City is keen to encourage business in the downtown that generates foot traffic and encourages customers to visit multiple businesses within the same trip. A brewpub in this location would be a welcome attracting and feature on this part of Main Street.

The majority of the beer served at this facility is made off site. The brewing equipment proposed for use here will be made in small batches, as the equipment capacity is 31 gallons. The applicant does not anticipate brewing more than 3,100 gallons per year and the majority of the beer will be consumed on site.

Sidewalk cafes are permitted temporary uses in the B-2 district. The applicant is welcome to offer outdoor seating in this location that adheres to the City's sidewalk café standards. The sidewalk café standards are included at the end of this report. It is on the applicant to adhere to those standards.

The zoning code lists two main standards for light industrial uses incidental to indoor sales:

- **The light industrial activity shall not exceed 15 percent of the total area of the buildings on the property.** The building itself is around 2,050 square feet. Therefore, industrial uses cannot exceed 310 square feet. The applicant indicates the brewing equipment will take up about 200 square feet.
- **The production area shall be physically separated by a wall from other activity areas and shall be soundproofed to the level required by this chapter.** There is a physical wall separating the brewing equipment from the dining area. The brewing equipment does not generate noise.

**Required Plan Commission findings for Conditional Use Permit request:** Section 130-104(3) of the Municipal Code, includes criteria that should be considered in making this decision:

1. **Consistency of the use with the comprehensive plan.** The proposed use in general and in this specific location is consistent with the city's comprehensive plan of October 2023.  
*Staff Comment: Policies in the Comprehensive Plan provide support for variety and diversification of uses in its historic downtown.*
2. **Consistency with the City's zoning code, or any other plan, program, or ordinance.** The proposed use in general and in this specific location is consistent with City's zoning code, or any other plan, program, or ordinance, whether adopted or under consideration pursuant to official notice of the city.  
*Staff comment: The proposed use is consistent with the City's zoning code and other plans, programs, and ordinances.*
3. **Effect on nearby property.** The use will not result in a substantial or undue adverse impact on nearby property, the character of the neighborhood, environmental factors, traffic factors, parking, public improvements, public property or rights-of-way, or other matters affecting the public health, safety, or general welfare, either as they now exist or as they may in the future be developed as a result of the implementation of the City's zoning code, the comprehensive plan, or any other plan, program, map, or ordinance adopted or under consideration pursuant to official notice by the city.  
*Staff Comment: The applicant states that the business will not be opened later than 10pm.*
4. **Appropriateness of use.** The use maintains the desired consistency of land uses, land use intensities, and land use impacts as related to the environs of the subject property.

*Staff Comment: The brewing equipment can be adequately served by this property.*

5. **Utilities and public services.** The use will be adequately served by, and will not impose an undue burden on, any of the improvements, facilities, utilities, or services provided by the City or any other public agency serving the subject property.

*Staff Comment: the property is currently served by public utilities*

**Required Plan Commission conclusion:** Section 130-104(3)(f) of the Municipal Code requires the Plan Commission to determine whether the potential public benefits of the conditional use do or do not outweigh any and all potential adverse impacts. The proposed motion below states that benefits do in fact outweigh any and all potential adverse impacts.

**Staff recommended motion for Plan Commission:** *Motion to approve issuance of a Conditional Use Permit for Light Industrial Use incidental to Indoor Sales to operate brewing equipment per section 130-530 on parcel of land 6-27-6 located at 18 E Main Street, finding that the benefits of the use outweigh any potential adverse impacts, and that the proposed use is consistent with the required standards and criteria for issuance of a CUP set forth in Section 130-104(3)(a) through (e) of the Zoning Ordinance, subject to the following condition that the Conditional Use Permit is recorded with the Rock County Register of Deeds.*

- 1) *The business operator, now and in the future, shall comply with all provisions in the City's Zoning Code, as may be amended, related to sidewalk cafes. (Section 130-568).*
- 2) *Hours of operation shall be no earlier than 9am and no later than 10pm.*
- 3) *The business operator shall obtain and maintain all City, state, and county permits and licenses as may be required.*
- 4) *Any substantial changes to the business model, such as significant increases in beer production or equipment, shall require a review of the existing conditional use permit.*
- 5) *A sign application and Certificate of Appropriateness approval, issued by the Historic Preservation Commission, is required for any planned signage related to the business.*
- 6) *Use cannot create a public nuisance as defined by local and state law.*
- 7) *The Conditional Use Permit is recorded with the Rock County Register of Deeds.*

**Sec. 130-568. Sidewalk cafés.**

Sidewalk cafés include an area on a sidewalk or similar area within the public right-of-way where food is served and which is associated with a restaurant. The provisions of this section are intended to accomplish the following purposes: enhance the pedestrian ambiance of the city by promoting additional activity on city sidewalks and visual interest, enhance the appropriate use of existing public spaces; and increase economic activity in the area. This use is a permitted use in the B-2 district. Temporary use regulations are as follows:

- (1) *Location.* A sidewalk café shall be located directly in front of the restaurant with which it is associated and it shall be operated solely in conjunction with such restaurant.
- (2) *Obstructions.* A sidewalk café may not interfere with any public service facilities located within the street right-of-way, including public telephones, mailboxes, public signs, public benches, public art, public fountains, and bus stops. In addition, a sidewalk café may not interfere with fire escapes, drop ladders, building access points, and other points of normal or emergency access.
- (3) *Pedestrian movement.* No portion of the sidewalk café may impede pedestrian movement. Generally, a 4-foot wide unobstructed walkway allows adequate pedestrian movement.
- (4) *Planters.* Planters may be used as a visual amenity and to frame off the space allocated for the sidewalk café. The size of plant materials shall be compatible in scale with the immediate area. Hanging planters are not permitted.
- (5) *Lighting.* Lighting shall be limited to tabletop lamps of low intensity. The city administrator may allow additional lighting to provide appropriate levels for safety.
- (6) *Furnishings.* All furnishings shall fit the character of a public streetscape. Umbrellas over each table may be permitted if it does not create an obstruction.
- (7) *Floor covering.* A floor covering may not be used in the sidewalk café.
- (8) *Tables.* Round tables may not exceed 36 inches in diameter and square tables may not exceed 36 inches in width.
- (9) *Food preparation.* All food shall be prepared within the restaurant.
- (10) *Alcoholic beverages.* No alcoholic beverages may be served or consumed in the sidewalk café unless the proper licenses have been issued under Sec. 6-2, Sec. 6-43, and or Sec. 106-163.
- (11) *Off-street parking requirements:* One space per every three patron seats, calculated on the sum of the indoor and outdoor patron seats. This requirement may be waived by the plan commission, following a request from the applicant.

[Ord. 2005-21, Ord. 2022-05]



## APPLICATION FOR CONDITIONAL USE PERMIT- STAFF REPORT

**Application:** 2023-0060 **Applicant:** Joel Tomlin

Parcel 6-27-894.1

March 31, 2023

Prepared by: Colette Spranger, Community Development Director  
 Direct questions and comments to: [colette.spranger@ci.evansville.wi.gov](mailto:colette.spranger@ci.evansville.wi.gov) or 608-882-2263



**Description of request:** An application for a conditional use permit on parcel 6-27-894.1 located at 30 Railroad Street has been submitted for consideration by the Plan Commission. The request is to construct a new garage in the Historic Conservation Overlay District. The Parcel is zoned R-2 Residential Two. As per section 130-1123 (a) of the Evansville Zoning Ordinance a CUP is required for all new construction or expansions of existing uses.

**Staff Analysis of Request:** The proposal is believed to meet the minimum standards of the Historic Conservation (HC) overlay district. HPC has reviewed the proposal and recommended approval, including a request to widen the driveway from 17 to 20 feet.

**Required Plan Commission findings for Conditional Use Permit request:** Section 130-104 (3) of the Municipal Code, includes criteria that should be considered in making this decision:

- Consistency of the use with the comprehensive plan.** The proposed use in general and in this specific location is consistent with the city's comprehensive plan of October 2022.  
*Staff Comment: The Comprehensive plan indicates a desire to promote good stewardship of the Historic Districts.*
- Consistency with the City's zoning code, or any other plan, program, or ordinance.** The proposed use in general and in this specific location is consistent with City's zoning code,

or any other plan, program, or ordinance, whether adopted or under consideration pursuant to official notice of the city.

*Staff comment: The proposed construction is consistent with the City's zoning code and other plans, programs, and ordinances. Per Division 20 of Chapter 130, front yard setbacks can be determined based on the average of those of neighboring properties. Along Railroad Street, that average is 8 feet. Therefore, the proposed garage will be outside the front yard area. A 3 foot setback will be maintained at the side yard.*

3. **Effect on nearby property.** The use will not result in a substantial or undue adverse impact on nearby property, the character of the neighborhood, environmental factors, traffic factors, parking, public improvements, public property or rights-of-way, or other matters affecting the public health, safety, or general welfare, either as they now exist or as they may in the future be developed as a result of the implementation of the City's zoning code, the comprehensive plan, or any other plan, program, map, or ordinance adopted or under consideration pursuant to official notice by the city.

*Staff Comment: No adverse effect is anticipated on nearby property. The applicant intends to match the color of the garage to the house.*

4. **Appropriateness of use.** The use maintains the desired consistency of land uses, land use intensities, and land use impacts as related to the environs of the subject property.

*Staff Comment: A detached garage to a residential single family home is an appropriate use in the R-2 district.*

5. **Utilities and public services.** The use will be adequately served by, and will not impose an undue burden on, any of the improvements, facilities, utilities, or services provided by the City or any other public agency serving the subject property.

*Staff Comment: the property is connected to public utilities.*

**Additional Findings:** Section 130-1123(b) of the Municipal Code requires the Plan Commission to determine whether the proposal meets general design criteria. Specifically, the section reads, "In general, the following items shall be considered in making decisions about conditional use requests within this district." Staff comments are found below regarding the design criteria to be reviewed:

- (1) *Height. All new structures should be constructed to a height visually compatible with the buildings and environment with which they are visually related. **Staff Comment: The height does not detract from that of adjacent buildings.***
- (2) *Scale. The gross volume of any new structure should be visually compatible with the buildings and environment with which it is visually related. **Staff Comment: Overall addition volume is similar to that of other outbuildings in the vicinity.***
- (3) *Proportion of front facades. In the street elevation of a building, the proportion between the width and height in the facade should be visually compatible with the buildings and environment with which it is visually related. **Staff Comment: the front façade does not detract from neighboring buildings.***
- (4) *Proportion of openings. The proportions and relationships between doors and windows in the street facades should be visually compatible with the buildings and environment with which they are visually related. **Staff Comment: The garage door opening on front façade is compatible with neighboring buildings.***



- (5) *Rhythm of solids to voids. The rhythm of solids to voids created by openings in the facade should be visually compatible with the buildings and environment with which it is visually related. **Staff Comment: solids and voids of the proposed garage are balanced.***
- (6) *Rhythm of spacing. The existing rhythm created by existing building masses and spaces between them should be preserved. **Staff Comment: Addition is properly spaced from neighboring structures.***
- (7) *Relationship of materials. The materials used in the final facades should be visually compatible with the buildings and environment with which they are visually related. **Staff Comment: Neighboring buildings use a variety of materials including wood, aluminum, and vinyl. The proposed building will use vinyl siding that does not feature a wood grain texture.***
- (8) *Relationship of textures. The texture inherent in the facade should be visually compatible with the buildings and environment with which it is visually related. **Staff Comment: Neighboring buildings consist of horizontal siding elements and asphalt roofing. The proposed addition will have these same elements.***
- (9) *Relationship of roofs. The design of the roof should be visually compatible with the buildings and environment with which it is visually related. **Staff Comment: Neighboring buildings consist of asphalt roofs. The proposed addition will have these same elements.***
- (10) *Landscaping. The landscape plan should be sensitive to the individual building, its occupants and their needs. Further, the landscape treatment should be visually compatible with the buildings and environment with which it is visually related. **Staff Comment: No landscaping is shown on site plans. Some evergreen shrubs/trees will be removed to make room for the garage, but larger trees in the back of the yard will be preserved.***
- (11) *Directional expression of front elevation. All street facades should blend with other buildings via directional expression. When adjacent buildings have a dominant horizontal or vertical expression, this expression should be carried over and reflected. **Staff Comment: Proposed addition maintains a horizontal direct expression, similar to the primary residence.***
- (12) *Relationship of architectural details. Architectural details should be incorporated as necessary to relate the new with the old and to preserve and enhance the inherent characteristics of the area. **Staff comment: Architectural details on the proposed building are minimal. Historic preservation discussed and approved the building with minimal details.***

**Required Plan Commission conclusion:** Section 130-104(3)(f) of the Municipal Code requires the Plan Commission to determine whether the potential public benefits of the conditional use do or do not outweigh any and all potential adverse impacts. The proposed motion below states that benefits do in fact outweigh any and all potential adverse impacts. The recommended motion includes a condition.

Staff recommended motion: *Plan Commission approves issuance of a Conditional Use Permit for a new garage on parcel 6-27-894.1, finding that the benefits of the use outweigh any potential adverse impacts, and that the proposed use is consistent with the required standards and criteria for issuance of a CUP set forth in Section 130-104(3)(a) through (e) of the Zoning Ordinance, subject to the following condition:*

1. *Any variation from Historic Preservation Commission approved plans including exterior materials.*

## 2-Car Garage 24' x 24' x 8' Material List

Advanced House Plans Plan # 29993

Model Number: 1950478 | Menards® SKU: 1950478



Roof Framing Type: Spread Web Truss

### Sold In Stores

Stop by any Menards for information and to purchase.

Description & Documents ^

2-Car Garage 24' x 24' x 8' Material List

Brand Name: **Menards****Features**

- Cutting and assembly required
- 1/2" OSB roof sheathing
- Aluminum soffit and fascia included
- Includes roof edge, nails and hardware
- Building plans included
- Materials can be modified to your personal preference, price subject to change
- Due to local state, city, county or municipality code requirements this plan may not completely comply with those building codes. It's recommended to consult with your local building official prior to purchasing the plan. If needed, plans can be modified to comply with any state, city, county or municipality code requirements. Modification fee may apply.

Specifications ^

Product Type	Garage	Garage Type	2 Car
Foundation Type	Slab	Entry Style	Gable
Overall Width	24 foot	Overall Length	24 foot
Sidewall Height	8 foot	Square Footage	576 square foot
Exterior Wall Framing	2x4 Stud	Roof Framing Type	Truss
Rafter/Truss Spacing	2 foot	Roof Pitch	4/12
Roofing Type	3-Tab Shingles	Siding Type	D4 Vinyl
Soffit Type	Aluminum	Overhead Door Quantity	1
Overhead Door Size	16 x 7	Service Door Quantity	1
Service Door Size	36 x 80	Window Quantity	1
Window Size	36 x 24	Includes	Materials Include Framing, 24" On Center Trusses, Roofing, Siding, Soffit, Fascia, One 16x7 Overhead Door, One Service Door, Window, and Plans
Shipping Weight	8243.0 lbs	Return Policy	Regular Return ( <a href="#">view Return Policy</a> ).

**Please Note:** Prices, promotions, styles and availability may vary by store and online. Inventory is sold and received continuously throughout the day; therefore, the quantity shown may not be available when you get to the store. This inventory may include a store display unit. Online orders and products purchased in-store qualify for rebate redemption. Mail-in Rebate is in the form of merchandise credit check, valid in-store only. Merchandise credit check is not valid towards purchases made on MENARDS.COM®. By submitting this rebate form, you agree to resolve any disputes related to rebate redemption by binding arbitration and you waive any right to file or participate in a class action. Terms and conditions available at [www.rebateinternational.com](http://www.rebateinternational.com)®





/// new pavement      - - - - setback lines



CITY OF EVANSVILLE  
ORDINANCE #2023-03

AMENDING CHAPTERS 130, ARTICLE IV. Landscaping Regulations

The Common Council of the City of Evansville, Rock County, Wisconsin, amend Evansville Municipal Code Chapter 130 as follows:

\*\*\*\*\*

ARTICLE IV. LANDSCAPING REGULATIONS

Sec. 130-261. Purpose of article.

The purpose of this article is to provide minimum requirements for landscaping and landscaping plans based on the amount of impervious surface on a lot or combination of lots proposed for development.

(Ord. No. 1997-18, § 12(17.601), 1-19-1998, Ord. 2010-02)

Sec. 130-262. Intent, scope and organization of article.

(a) This article contains the standards that govern the amount, size, type, installation and maintenance of required landscaping. This article recognizes the important and diverse benefits which landscaping provides in terms of protecting the health, safety, and general welfare of the community, ~~and as well as~~ implementing the ~~master~~ comprehensive plan. The requirements of this article are intended to:

- (1) Protect and restore the natural environment throughout the development process.
- (2) Reduce the negative environmental effects of development while fostering aesthetically pleasing development which will enhance the appearance and character of the community.
- (3) Reduce the “heat island” effect of impervious surfaces such as parking lots by cooling the shading the surface area.
- (4) Increase the compatibility of adjacent uses, by minimizing adverse impacts of noise, dust and other debris, motor vehicle headlight glare or other artificial light intrusions and other objectionable views, activities or impacts to adjacent or surrounding uses.

(b) The landscaping requirements described in this article are required for all new developments and expansions of existing developments, except single-family and two-family residential dwellings.

(c) A "landscaping point" concept is used to provide a maximum amount of flexibility and individual preference in terms of the selection of plant materials.

(d) The landscaping proposed by the applicant shall address the following areas that generally require landscape treatments:

- (1) Building foundations
- (2) Street yard beautification
- (3) Parking lot and loading area screening
- (4) Buffer areas between potentially conflicting land uses
- (5) Screening of site elements, such as trash and outside storage areas

(Ord. No. 1997-18, § 12(17.602), 1-19-1998, Ord. 2010-02)

**Sec. 130-263. Required landscaping points and landscaping plan.**

(a) *Landscaping points.* Landscaping requirements are stated in terms of the number of landscaping points required. The required number of landscaping points is dependent upon the amount of impervious surface on a lot or combination of lots proposed for development based on the landscape point requirements described in Table 1 below:

**Table 1. Landscape Point Requirements**

<i>Impervious Surface</i>	<i>Required Points</i>
Under 10,000 SF	100 points per 1,000 SF
10,000 to 19,999 SF	80 points per 1,000 SF
20,000 to 49,999 SF	60 points per 1,000 SF
50,000 SF and Over	40 points per 1,000 SF

For purposes of interpreting this requirement, impervious surfaces include all area under principal and accessory buildings, parking areas, and paved surfaces.

(b) *Point Scoring.* A different number of points are awarded for each plant, depending upon its typical growth rate, its mature height, and whether it is a deciduous or evergreen species. There is a minimum plant size at the time installation in order for plants to be eligible for landscape points. In calculating the number of required landscaping points under the provisions of this article, all areas and distances for which required calculations are based shall be rounded up to the nearest whole number. Table 2 below describes the points awarded for different plant categories.

**Table 2. Landscape Points Per Plant and Minimum Installation Sizes**



<i>Plant Category</i>	<i>Landscape Points per Plant</i>	<i>Minimum Permitted Plant Installation Size</i>
Tall deciduous tree (40 to 100 feet)	50	2" caliper
Medium deciduous tree (30 to 40 feet)	30	6' tall
Low deciduous tree (15-30 feet)	20	4' tall
Evergreen tree	40	5' tall
Tall deciduous shrub (8 to 10 feet)	10	36" tall
Medium deciduous shrub (5 to 8 feet)	4	24" tall
Low deciduous shrub (2 to 5 feet)	2	18" tall
Tall to medium evergreen shrub	8	18" tall/wide
Low evergreen shrub	2	12" tall/wide
Decorative screening fence	1 point per linear foot	N/A

(c) *Existing plant material.* Existing plant materials on site may be included in point calculations, if the materials are non-invasive, desirable species and will be preserved and protected during construction.

(d) *Landscaping Plan.* Plant materials and other elements of landscaping required to meet the standards of this article shall be clearly depicted and labeled on a landscaping plan. Landscaping plans may be prepared by an owner, a landscape company, landscape architect, or other qualified landscape professional. Landscaping plans shall include:

- (1) Notation of drawing scale and directional north arrow
- (2) Name, address and phone number of the owner and the person who prepared the plan.
- (3) Location of existing deciduous trees greater than three-inch caliper and evergreen trees 10 feet high or greater
- (4) Description of plant materials to be removed
- (5) Location and schedule of proposed new plant materials listing the common name and botanical name of proposed plant materials, quantity, and plant size at installation.

- (6) Location and description of all proposed walls, fences, and other similar site landscape features.
- (7) Labeling of mulching, edging & curbing
- (8) Areas of seeding or sodding
- (9) Areas to remain undisturbed and limits of land disturbance

(e) *Landscaping plan review and approval.* Landscaping plans shall be reviewed and approved by the Plan Commission as part of the site plan review and approval process described in Article II Division 8 of this chapter.

(f) *Additional landscaping or screening.* Additional landscaping or screening may be required by the Plan Commission in order achieve the intent of this section as described in Section 130-262.

(g) *Exceptions: During Site Plan approval, the Plan Commission, or during project implementation, City staff, may grant exceptions to the allow required landscaping to be planted offsite for the shared benefit of the community. Offsite plantings are only allowed if the applicant demonstrates point requirements stated in this section in situations where there is sufficient existing or proposed landscaping to meet the intent of this article as described in Section 130-262. Landscaping placed offsite is subject to the following priorities:*

- (1) *Trees planted in adjacent terraces,*
- (2) *Trees planted in terraces in general,*
- (3) *Landscaping installed on City owned property,*
- (4) *Fees paid equivalent to value of landscaping points for the maintenance, installation, or improvement of landscaping at city facilities and recreation areas,*

(g) *Under no circumstances should 100% of required landscaping points be subject to exceptions described above*

(Ord. No. 1997-18, § 12(17.603), 1-19-1998, Ord. 2010-02, Ord. 2011-07)

**Sec. 130-264. Plants Suitable for South Central Wisconsin**

Common species suitable for landscaping use in south central Wisconsin are listed in *A Guide to Selecting Landscape Plants for Wisconsin*, E.R. Hasselkus, UW Extension Publication: A2865, which is adopted by reference as a part of this section. The City and applicants shall use this publication as a guideline for plant selection.

(Ord. 2011-07)

**Sec. 130-265. Installation and maintenance of landscaped areas.**

Formatted: Font: Not Italic

Formatted: Font: Not Italic

Formatted: Font: Not Italic

Formatted: Font: Not Italic

Formatted: No bullets or numbering

(a) *Installation.*

- (1) All landscaping material required by the provisions of this article shall be installed on the subject property, in accordance with the approved landscaping plan, within 365 days of the issuance of an occupancy permit for any building on the subject property.
- (2) All new plant materials credited for landscape points shall be nursery-grown stock grown in accordance with the *USA Standards for Nursery Stock*, latest edition. All plants shall be hardy plants suitable for south central Wisconsin climatic conditions. All plants shall be typical of their species or variety and shall have a normal habit of growth. Installed plant materials shall be sound, healthy and vigorous, well-branched and densely foliated when in leaf with healthy, well-developed root systems. They shall be free of disease and insect pests, eggs, or larvae.
- (3) All pervious portions of each lot, not otherwise landscaped, shall be seeded with lawn or native ground cover unless such vegetation is already fully established.
- (4) Landscaping materials, fences and berms which are located within duly recorded utility easements and/or pedestrian easements shall be located and selected so that they will not interfere with the intent of the easement. In the event of construction activity or maintenance within a recorded easement, replacement of any plant materials or landscape features in an easement shall be the responsibility of the property owner.
- (5) On corner lots in all zoning districts, no fence, wall, vegetation, hedge, planting, or structure shall be erected, placed, planted, or allowed to grow in such a manner as to obstruct the vision clearance triangle between a height of 2 1/2 feet and ten feet above the centerline grades of the intersecting streets in the area bounded by the edge of right-of-way street lines of such corner lots and a line joining the points along such street lines 15 feet from the point of intersection. If arterial streets intersect with other arterial streets or railways, the triangular vision clearance triangle shall be increased to 30 feet from the point of intersection.
- (6) Private parking areas on non-residentially zoned parcels in excess of 10,000 SF or 25 spaces shall include internal landscaping and islands equal to 15% of parking area.
- (7) At least two street trees shall be planted in the terrace adjacent to each lot at time of construction or when improvement to the property exceed 25% of the land value.

(b) *Maintenance.*

**Formatted:** List Paragraph, No bullets or numbering, Adjust space between Latin and Asian text, Adjust space between Asian text and numbers

**Formatted:** List Paragraph, No bullets or numbering, Adjust space between Latin and Asian text, Adjust space between Asian text and numbers

- (1) The continued and continual maintenance of all required landscaping materials and ground cover shall be the responsibility of the owner of the property on which the materials are required. Plant material that has died shall be replaced within 365 days. This requirement shall run with the property and is binding upon all future property owners.
- (2) The owner of any lot or parcel in the city which is five acres or less in area shall maintain lawns, turf areas, plantings beds, and other decorative surface treatments, so as to present an attractive appearance in all yard areas in accordance with generally accepted landscaping practices in south central Wisconsin.
- (3) Lawns shall be maintained to a height not to exceed 8 inches.

(4) At least one street tree shall be maintained in the terrace adjacent to each lot

(Ord. No. 1997-18, § 12(17.613), 1-19-1998, Ord. 2010-02, Ord. 2011-07)

**Secs. 130-266 -- 130-300 Reserved.**

(Ord. No. 1997-18, § 12(17.604-612, 614), 1-19-1998; Ord. No. 1998-12, § 4(17.604-607,610), 9-8-1998, Ord. 2005-40, Ord. 2005-44, Ord. 2010-02, Ord. 2011-07)

\*\*\*\*\*  
This Ordinance shall be in full force and effect upon passage and publication.

Passed and adopted this \_\_\_\_ day of \_\_\_\_\_, 2023.

\_\_\_\_\_  
Dianne C. Duggan, Mayor

\_\_\_\_\_  
Leah L. Hurtley, City Clerk

Introduced: 04/04/2023  
First Reading:04/11/2023  
Adoption: 05/09/2023  
Publication: 05/00/2023

